

Pachyderm

1996

Number 21

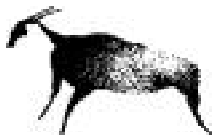



SPECIES
SURVIVAL
COMMISSION

Pachyderm

1996

Number 21

Contents

-
- 1 Chairman's Report: Asian Rhino Specialist Group
*Mohd Khan bin Momin Khan
with Thomas J. Foose*
-
- 2 Rapport du Président: Groupe de Spécialistes du
Rhinocéros Asiatique
*Modh Khan bin Momin Khan
avec Thomas J. Foose*
-
- 3 Chairman's Report: African Rhino Specialist Group
Martin Brooks
-
- 5 Rapport du Président: Groupe de Spécialistes du
Rhinocéros Africain
Martin Brooks
-
- 7 Chairman's Report: African Elephant Specialist Group
Holly T. Dublin
-
- 9 Rapport de la Présidente: Groupe de Spécialistes de
l'Éléphant Africain
Holly T. Dublin
-
- 12 Letter to the Editor
Clive A. Spingale
-
- 13 The Sumatran Rhino in Way Kambas National Park,
Sumatra, Indonesia
*Dwiatmo Siswomartono, Suherti Reddy,
Widodo Ramono, Jansen Manasang,
Ron Tilson, Nell Franklin and Tom Foose*
-

Editor

Ruth Change

Editorial Board

Holly Dublin
Chryssee Martin
Esmond Bradley Martin
Mark Stanley Price
Nico Van Strien
Lucy Vigne
Clive Walker

All correspondence, including
enquiries about subscription,
should be sent to:

The Editor
Pachyderm
WWF Regional Office
PO Box 62440
Nairobi, Kenya
Tel: 254-2-331543/332963
Fax: 254-2-332878

Publication costs for this issue have
been provided by the United States
Fish and Wildlife Service

IUCN
The World Conservation Union



Cover photo: Mother and baby greater one-horned rhino in Kaziranga National Park,
Assam, India Photo credit: Lucy Vigne

- 15 The Sumatran Rhinoceros in Kalimantan, Indonesia:
Its Possible Distribution and Conservation Prospects
Erik Meijaard
-
- 24 Mating Sumatran Rhinoceros at Sepilok Rhino Breeding
Centre, Sandakan, Sabah, Malaysia
Edwin J. Bosi
-
- 28 Smuggling Routes for West Bengal's Rhino Horn and
Recent Successes in Curbing Poaching
Esmond B. Martin
-
- 35 A Photographic Method for Identifying Black Rhinoceros
Individuals
Max Morgan-Davies
-
- 38 Status of the Black Rhinoceros in the Masai Mara National
Reserve, Kenya
Max Morgan-Davies
-
- 46 Observations on two Introduced Black Rhinos in Liwonde
National Park, Malawi
Roy Bhima and C. O. Dudley
-
- 55 Ultrasonography as a Tool in the Conservation of the African
Rhinoceros: ex situ and in situ Applications
*Robin W Radcliffe, Meg P. Bommarito
and Steven A. Osofsky*
-
- 60 Is Rhino Dehorning Scientifically Prudent?
Joel Berger and Carol Cunningham
-
- 69 A Nationwide Survey of Crop-Raiding by Elephants and
other Species in Gabon
Sally A. Lahm
-
- 78 African Elephants in Coastal Refuges
Joseph P. Dudley
-
- 84 Notice to Contributors
-

ERRATA

The Figure caption in the article by Osofsky, Rogers & Trawford (1995) in *Pachyderm* 20 was incomplete. It should read: Khama Rhino Sanctuary bomas 1 to 4 and paddocks (not to scale). The front of the bomas are at the bottom of the diagram. The front of each boma is five metres long. The side walls of each boma are 43m long. The back wall of each boma is 21 m across. The side walls of each paddock are 80m long. The back wall of each paddock is 60m across. Internal gates are indicated by bold lines.

CHAIRMAN'S REPORT: ASIAN RHINO SPECIALIST GROUP

Mohd Khan bin Momin Khan¹, Chairman, with Thomas J. Foose²
and Nico J. van Strien³, Programme Officers

¹Forestry Dept., ITTO Unit, 5th Floor, Wisma Sumber Alam, Petra Jaya, Jalan stadium, 93600 Kuching Sarawak, Malaysia ²International Rhino Foundation, c/o The Wilds, 14000 International Road, Cumberland OH 43215, USA ³Julianaweg 2, 3941 DM Doorn, Netherlands

The Asian Rhino Specialist Group (AsRSG) conducted a plenary meeting in Sandakan, Sabah, at the end of November 1995. The major focus of the meeting was the completion of the revised AsRSG action plan -*Asian Rhinos: An Action Plan for Their Conservation*. Formal publication will occur before the IUCN General Assembly, which takes place in October 1996. A population and habitat viability assessment (PHVA) workshop for the Malaysian rhino was conducted just before the AsRSG meeting. A report will be published by July 1996.

Notable at the AsRSG meeting were reports of continued growth of the populations of *Rhinoceros unicornis* in both India and Nepal, although poachers pose a significant challenge in both countries. The situation for *Dicerorhinus sumatrensis* is precarious and has continued to deteriorate despite intensified *in situ* efforts. Poaching pressure seems to have also increased for *Rhinoceros sondaicus* in Indonesia, despite considerable increase in protection activities. One *R. sondaicus* was lost in 1994, which is significant in such a small and intensively protected population. The situation for this species in Vietnam is uncertain. A major World Wildlife Fund project is being implemented for Nam Cat Tien National Park but the remnant rhino population lives outside this protected area and the project's plans for specific rhino activities are unclear.

The revised AsRSG action plan also contains much more explicit explanation of the programmes/projects and their costs, as a basis for pursuing a funding strategy for Asian rhino conservation.

The Global Environment Fund project to initiate implementation of the Conservation Strategy for Rhinoceros in Indonesia and Malaysia has now been in progress for a year. The first formal annual review will be conducted in May 1996. Training and deployment of more intensive anti-poaching teams in both nations, as well as improvement in the institutional capacity for co-ordination of rhino conservation, have progressed well. Less encouraging has been the discovery, while the anti-poaching teams have been working, of further decline of the Sumatran rhino population in some of the major areas which they inhabit, notably Kerinci Seblat National Park in Sumatra, Indonesia, and Endau Rompin State Park(s) in Peninsular Malaysia.

Progress continues on the development of managed breeding centres for Sumatran rhinos in native habitat, under more natural conditions. The expansion of the enclosures at Sungai Dusun in Peninsular Malaysia has been completed under the auspices of the AsRSG, with grants from and through the International Rhino Foundation. Rhinos will be released into the new areas soon. After some delays due to the unusually heavy and long rains in Sumatra this year, construction has finally commenced on the managed breeding centre, currently being designated a Sumatran Rhino Sanctuary (SRS), in Way Kambas National Park. It is expected that the first rhinos will be repatriated to the SRS from zoos in Indonesia by the end of July 1996.

The second issue of the new AsRSG newsletter *Asian Rhinos* was published in October 1995. The next issue will be published in June 1996.

RAPPORT DU PRESIDENT: GROUPE DE SPECIALISTES DU RHINOCEROS ASIATIQUE

Mohd Khan bin Momin Khan¹, Président, avec Thomas J. Foose²
et Nico J. van Strien³, responsables de programmes

¹Forestry Dept., ITTO Unit, 5th Floor, Wisma Sumber Alam, Petra Jaya, Jalan Stadium, 93600 Kuching Sarawak, Malaisie ²International Rhino Foundation, c/o The Wilds, 14000 International Road, Cumberland OH 43215, USA ³Julianaweg 2, 3941 DM Doorn, Pays-Bas

Le Groupe de Spécialistes du Rhinocéros Asiatique (GSRAs) a tenu une réunion plénière à Sandakan, Sabah, à la fin de novembre 1995. Le principal objet de la réunion était de compléter le plan d'action révisé du GSRAs - *Rhinos asiatiques: un Plan d'Action pour leur Conservation*. Sa publication officielle est attendue avant l'Assemblée générale de l'UICN qui aura lieu en octobre 1996. Juste avant la réunion du GSRAs, on avait réuni un atelier sur l'évaluation de la viabilité de la population et de l'habitat du rhinocéros de Malaisie. Le rapport en sera publié en juillet 1996.

Lors de la réunion du GSRAs, il a fallu remarquer les rapports sur la poursuite de l'augmentation des populations de *Rhinoceros unicornis* tant en Inde qu'au Népal, encore que les braconniers constituent un problème significatif dans les deux pays. La situation de *Dicerorhinus sumatrensis* est précaire et a poursuivi sa détérioration malgré l'intensification des efforts sur le terrain. La pression du braconnage semble s'être aussi accrue sur *Rhinoceros sondaicus* en Indonésie malgré l'augmentation considérable des activités de conservation. On a perdu un *R. sondaicus* en 1994, ce qui est significatif dans une population si réduite et si intensément protégée. Le statut de cette espèce au Vietnam est incertain. Le Fonds mondial pour la nature est en train de réaliser un important projet au Parc National de Nam Cat Tien, mais la population restante de rhinos vit en dehors de cette aire protégée, et le programme du projet pour des activités spécifiquement liées aux rhinos n'est pas clair.

Le plan d'action révisé du GSRAs comprend aussi une explication beaucoup plus claire des programmes et des projets et de leur coût, qui doit servir de base pour la poursuite de la stratégie de financement de la conservation des rhinos asiatiques.

Le projet du Fonds pour l'environnement mondial pour lancer la réalisation de la Stratégie de Conservation des Rhinocéros en Indonésie et en Malaisie est maintenant en route depuis un an. La première révision annuelle officielle aura lieu en mai 1996. La formation et le déploiement de patrouilles antibraconnage plus intensives dans les deux pays, ainsi que l'amélioration du potentiel institutionnel de coordination de la conservation des rhinos ont bien avancé. Il a été plus décourageant de découvrir que, alors que les patrouilles antibraconnage étaient au travail, les populations de rhinocéros de Sumatra on poursuivi leur déclin dans plusieurs des plus importantes régions qu'ils occupent, particulièrement le Parc National de Kerinci Seblat, à Sumatra, en Indonésie, et le(s) parc(s) de l'état d'Endau Rompin, dans la Péninsule Malaise.

Le développement de centres de reproduction dirigée pour les rhinocéros de Sumatra progresse dans leur habitat d'origine, dans des conditions plus naturelles. L'extension des enclos de Sungai Dusun, dans la péninsule Malaise, s'est terminée sous les auspices du GSRAs, grâce à des fonds provenant de ou par la International Rhino Foundation. Les rhinos seront bientôt relâchés dans les nouveaux emplacements. Après un certain retard dû aux pluies particulièrement longues et abondantes cette année à Sumatra, les constructions ont finalement commencé au centre de reproduction dirigée, désigné actuellement sous le terme de Sanctuaire pour le Rhinocéros de Sumatra (SRS), au Parc National de Way Kambas. On espère que les premiers rhinos reviendront des zoos indonésiens au SRS vers la fin de juillet 1996.

Le deuxième numéro du nouveau journal du GSRAs sur les rhinos asiatiques a été publié en octobre 1995. Le prochain numéro paraîtra en juin 1996.

CHAIRMAN'S REPORT: AFRICAN RHINO SPECIALIST GROUP

Martin Brooks

Natal Parks Board, PO Box 662, Pietermaritzburg 3200, South Africa

The third meeting of the African Rhino Specialist Group (AfRSG) was held in Itala Game Reserve in KwaZulu-Natal, South Africa, from 12-17 February 1996, and was attended by 30 members and contributors from 14 different countries, mainly African range states. This was followed by a two-day trip to the Hluhluwe-Umfolozi Park, during which the Natal Parks Board's conservation management programmes for both the black and southern white rhino were presented and discussed.

The meeting comprised reports from the range states, a re-assessment of the status and trends of Africa's

rhinos, the identification of key and important rhino populations, and presentations and discussions on a wide variety of issues relating to trade, conservation and management techniques and strategies. In addition, during workshops, the system for rating rhino conservation projects and programmes was revised to include a category for projects of national importance, a terms of reference of the monitoring assistance mission to Garamba National Park was developed, and definitions of wild and captive breeding, as well as some indicators to develop the effectiveness of rhino conservation measures as required by CITES, were developed.

Table. Numbers of white and black rhinos in Africa, by country and subspecies, in 1995 (Compiled at the February 1995 AfRSG meeting.)

COUNTRY	WHITE RHINO		TOTAL <i>cottoni</i>	TREND	BLACK RHINO				TOTAL	TREND
	<i>C.s</i>	<i>C.s</i> <i>Simum</i>			<i>D.b.</i> <i>bicornis</i>	<i>D.b.</i> <i>longipes</i>	<i>D.b.</i> <i>michaeli</i>	<i>D.b.</i> <i>minor</i>		
BOTSWANA	20*		20*	Stable				?	?	Down
CAMEROON						7*			7*	Down?
ETHIOPIA							1*		1*	?
IVORY COAST	4		4	Up						
KENYA	122		122	Up			420*		420*	Up
MALAWI								2	2	Stable
NAMIBIA	107		107	Up	598				598	Up
SOUTH AFRICA	7095		7095	Up	29		33	962	1024	Up
SWAZILAND	41		41	Up				9	9	Stable
TANZANIA							22	10*	32	?
ZAIRE		31	31	Up						
ZAMBIA	5		5	Stable				?	?	Down?
ZIMBABWE	138		138	Stable				315	315	Stable
SUDAN			?	?						
ANGOLA			Extinct		?			?	?	
MOZAMBIQUE			Extinct					?	?	
TOTALS	7532	31	7563	Up	626	7	476	1298	2408	Stable

**Total excludes speculative guestimates and so true population size may possibly be higher. Speculative guestimates include animals listed as guestimates at the May 1994 AfRSG meeting and for which there is no new information. Speculative guestimates also include animals for which there is some circumstantial evidence that they exist (or have not been killed) but this evidence may be old or unreliable. Thus, the totals in the table do not include estimates for rhinos that are believed to be or may be present, but where there is very little or no information on their status.*

African rhino numbers and trends

The numbers and trends of black and white rhinos in the range states, presented in the table, are particularly encouraging and confirm the trends just established in 1994.

The numbers of southern white rhinos *Ceratotherium simum simum* increased to 7,532 from 6,784 in 1993, with five countries recording increases and none declines. The northern white rhino *C.S.cottoni* population in Zaire now stands at 29, after two rhino were poached in the first quarter of 1996.

The current black rhino estimate of 2,408, while appearing slightly lower than the estimates of 2,475 and 2,550 in 1992 and 1993 respectively, excludes speculative guestimates which account roughly for the difference. However, while the black rhino trend on the continental scale is stable, this is largely due to a combined increase of the South African and Namibian populations of 308 rhinos (23%) since 1993. Many countries continue to experience declines.

There are currently 11 "key" black rhino and 12 "key" white rhino populations, which are considered critical to the survival of the six recognised subspecies.

The incidence of recorded poaching declined during 1994-95 and the possible reasons for this were discussed. The high level of security currently applied in most of the large populations, the limited number of "soft" targets available, and supply exceeding demand in the consumer states were all possibly relevant, although it is extremely difficult to separate the effects of increased security and changes in trade dynamics. It may well be that poachers are targeting the few remaining areas where security programmes are poorly developed and poaching goes largely unrecorded.

Selection of conservation priorities

It was agreed that projects or programmes requiring external funding would be rated in one of three categories (in priority order): **Priority Continental**, **Important Continental** or **Nationally Important**. All the existing projects, and a number of new ones, have been rated and lists are available on request. The

highest priority projects are either linked to one of the 23 "key" rhino populations or address issues of national or international significance to the long-term survival of the various taxa.

Northern white rhino strategy

The future management of the 30 northern white rhinos in Garamba National Park, Zaire, and the nine in captivity (San Diego and Dvur Kralove) was discussed at a workshop held at White Oak, Florida, in October 1995. While a metapopulation management approach, as favoured by the AfRSG, was not adopted, the Zairian authorities expressed an interest in pursuing planning for a second wild population elsewhere in Africa. In addition, some consolidation of the captive rhinos at Dvur Kralove was agreed upon (subsequently to be put on hold due to development at San Diego) and the AfRSG was requested to evaluate the Garamba monitoring programme. The latter was subsequently expanded to include an assessment of the security programme, with the mission timed for late April 1996. The recent poaching of two rhinos in Garamba highlights the vulnerability of this population and underlines the extreme urgency of securing its safety and making decisions that will enhance the survival prospects of this taxon.

Continental Action Plan

Good progress has been made with compiling the new Action Plan for African rhinos and it should be completed and published by the middle of 1996. It will be a concise, yet comprehensive, document providing information on the distribution and status of African rhinos, conservation goals and conservation priorities.

Communication

The poor response to requests for short contributions to the proposed AfRSG newsletter has delayed publication of the first issue, although I am confident that this will appear during 1996. Communication with the Asian Rhino Specialist Group (AsRSG) was enhanced through the attendance of the Scientific Officer, Richard Emslie, at both the AsRSG meeting and at a population viability assessment workshop on the Sumatran rhino in late 1995.

RAPPORT DU PRESIDENT: GROUPE DE SPECIALISTES DU RHINOCEROS AFRICAIN

Martin Brooks

Natal Parks Board PO Box 662 Pietermaritzburg 3200, South Africa

La troisième réunion du Groupe de Spécialistes du Rhinocéros Africain (GSRAf) s'est tenue à la Itala Game reserve, au Kwazulu-Natal, en Afrique du Sud, du 12 au 17 février 1996 et a vu la participation de 30 membres et participants venus de 14 pays, surtout des états africains de l'aire de répartition. Elle a été suivie par une excursion de deux jours au Parc de Hluhluwe-Umfolozi, au cours de laquelle les programmes de gestion de la conservation tant du rhino noir que du rhino blanc du Nord ont été présentés et discutés avec l'Administration des Parcs du Natal.

La réunion comprenait des rapports des états de l'aire de répartition, une réévaluation du statut des rhinos

africains et des tendances ainsi que des présentations et des discussions sur toute une variété de sujets liés au commerce, à la conservation et aux techniques et stratégies de gestion. De plus, au cours des ateliers, on a revu le système de classification des projets et des programmes de conservation des rhinos pour y inclure une catégorie destinée aux projets d'importance nationale, on a mis au point les termes de référence pour la mission d'assistance au monitoring au Parc National de la Garamba et aussi des définitions pour la reproduction en captivité et en liberté, ainsi que certains indicateurs pour établir des mesures de l'efficacité de la conservation des rhinos, comme l'avait demandé la CITES.

Tableau Nombre de rhinos blancs et de rhinos noirs en Afrique, par pays et par sous-espèce (compilés à la réunion du GSRAf de février 1996).

PAYS	RHINO BLANC		TOTAL	TENDANCE	RHINO NOIR				TOTAL	TENDANCE
	C.s simum	C.s cottoni			D.b. bicornis	D.b. longipes	D.b. michaeli	D.b. minor		
BOTSANA	20*		20*	Stable				?	?	Baisse
CAMEROUN						7*			7*	Baisse?
ETHIOPIE							1*		1*	?
COTE D'IVOIRE	4		4	Hausse						
KENYA	122		122	Hausse			420*		420*	Hausse
MALAWI								2	2	Stable
NAMIBIE	107		107	Hausse	598				598	Hausse
AFRIQUE DE SUD A	7095		7095	Hausse	29		33	962	1024	Hausse
SWAZILAND	41		41	Hausse				9	9	Stable
TANZANIE							22	10*	32	?
ZAIRE		31	31	Hausse						
ZAMBIE	5		5	Stable				?	?	Baisse?
ZIMBABWE	138		138	Stable				315	315	Stable
SOUDAN			?	?						
ANGOLA			Eteint		?			?	?	
MOZAMBIQUE			Eteint					?	?	
TOTAUX	7532	31	7563	Hausse	626	7	476	1298	2408	Stable

**Le total exclut les estimations spéculatives, donc la taille de la population pourrait être plus élevée. Par estimations spéculatives, on entend les animaux estimés à la réunion du GSRAf de mai 1994 pour lesquels on n'a reçu aucune information ultérieure. Elles comprennent aussi les animaux pour lesquels il y a certaines preuves qu'ils existaient (ou n'auraient pas été tués), mais ces preuves seraient anciennes ou non fiables. Donc, le total du tableau ne comprend pas les estimations de rhinos dont on croit qu'ils existent ou qu'ils pourraient exister mais pour le statut desquels il n'y a que peu ou pas d'informations.*

Nombre des Rhinocéros Africains et Tendances

Les nombres et les tendances pour les rhinocéros noirs et les rhinocéros blancs dans les états de l'aire de répartition, présentés au tableau sont particulièrement encourageants et confirment les tendances établies en 1994.

Le nombre des rhinocéros blancs du Sud, *Ceratotherium simum simum*, a augmenté de 6,784 en 1993 à 7,532, cinq pays reportant un accroissement, et aucun une diminution. La population de rhinos blancs du Nord, *C.s.cottoni*, s'élevait à 29 individus après le braconnage de deux animaux pendant le premier trimestre de 1996.

L'estimation actuelles des rhinos noirs s'élève à 2,408, ce qui est un peu moins que les estimations de 2,475 et 2,550 en 1992 et 1993 respectivement, mais elle exclut les estimations spéculatives qui s'élèvent approximativement à la différence. Cependant, si la tendance pour les rhinos noirs est stable à l'échelle du continent, c'est dû principalement à l'augmentation observée chez les populations d'Afrique du Sud (30%) et de Namibie (23%) depuis 1993. Beaucoup de pays voient leur nombre de rhinocéros décliner davantage.

Il existe actuellement 11 populations-clés de rhinos noirs et 12 populations-clés de rhinos blancs, qui sont reconnue d'importance critique pour la survie des six sous-espèces reconnues.

L'incidence du braconnage relevé ein 1994-1995 a diminué, et l'on a discuté des raisons qui pourraient l'expliquer. Ainsi, on peut parler du haut degré de sécurité appliqué actuellement chez la plupart des grandes populations, du faible nombre de cibles "fragiles" et de l'excès de l'offre sur la demande dans les pays consommateurs, mail il est extrêmement difficile de distinguer les effets d'une amélioration de la sécurité des changements survenus dans la dynamique du commerce. En fait, il se pourrait que les braconniers se concentrent sur les quelques endroits restants où les programmes de sécurité sont peu développés et qu'ainsi le braconnage passe largement inaperçu.

Choix des priorités en matière de conservation

On a accepté que les projets ou les programmes qui nécessitent un financement extérieur soient classés dans une des trois catégories (par ordre de priorité): **Priorité, Continentale, Importance Continentale** ou **Importance Nationale**. Tous les projets existants et un certain nombre de nouveaux projets ont ainsi été classés,

et on peut obtenir les listes sur demande. Les projets qui bénéficient de la plus haute priorité concernent soit une des 23 populations-clés de rhinos, soit des aspects significatifs au niveau national ou international pour la survie à long terme des différents taxons.

Stratégie pour le rhino blanc du Nord

Pendant un séminaire qui s'est tenu à White Oak, en Floride, en octobre 1995, on a discuté de la future gestion des trente rhinocéros blancs du Nord qui vivent au Parc National de la Garamba, au Zaïre et des neuf autres qui sont en captivité (à San Diego et à Dvur Kralove). On n'a pas adopté l'approche de gestion en métapopulation, privilégiée par le GSRAF, mais les autorités zaïroises ont exprimé leur intérêt pour la poursuite du projet de seconde population en liberté ailleurs en Afrique. De plus, on s'est accordé sur une certaine consolidation des rhinos captifs de Dvur Kralove (qui devait être maintenue à cause des développements survenus à San Diego), et l'on a demandé au GSRAF de faire l'évaluation du programme de contrôle de la Garamba. Ce dernier fut alors élargi pour comprendre une évaluation du programme de sécurité, une mission étant prévue pour la fin avril 1996. Le récent braconnage de deux rhinos à la Garamba montre bien la vulnérabilité de cette population et justifie l'extrême urgence qu'il faut accorder à sa sécurité et aux décisions à prendre pour améliorer les chances de survie de ce taxon.

Plan d'Action à l'échelle du Continent

La compilation du Plan d'action pour les rhinos africains a bien progressé; elle devrait être terminée et publiée vers le milieu de cette année. Ce sera un document concis, mais complet, qui donnera des informations sur la distribution et le statut des rhinos africains, sur les objectifs de leur conservation et les priorités à respecter.

Communication

Nous avons demandé de brèves contributions pour le journal que le GSRAF se propose de publier, le trop petit nombre de réponses reçues a retardé la parution du premier numéro mais je suis certain qu'il verra le jour au cours de 1996. La communication avec le Groupe de Spécialistes du Rhinocéros Asiatique (GRSAs) a été renforcée grâce à la participation du Responsable scientifique Richard Emslie à la réunion du GSRAF et à un atelier du PVA sur le rhinocéros de Sumatra, fin 1995.

CHAIRMAN'S REPORT: AFRICAN ELEPHANT SPECIALIST GROUP

Holly T. Dublin

WWF Regional Office, PO Box 62440, Nairobi, Kenya

Meeting in Kruger

From the 4th to the 11th of February 1996, the African Elephant Specialist Group (AfESG) held a membership meeting in Kruger National Park, South Africa. The Group was represented by a large turnout of nearly three-quarters of the members. It was a memorable meeting in several ways. On a technical level, members from around the continent presented updates on topics such as elephant translocation, human-elephant conflict, deterrence of crop-raiding elephants, tusklessness, forest and savanna elephant population dynamics, new survey results, elephant impact on habitats and progress with regard to research on elephant contraception. The current status of growing ivory stockpiles across the continent and the threats to safeguarding and securing them were explained to the Group. We listened with concern and frustration to reports from Central Africa about renewed elephant poaching and illegal ivory trading, inadequate legislation and judicial systems, exacerbated by massive corruption, and a desperate lack of government resources to combat these problems. On the encouraging side, we heard of the recent successes of the ELESMAF project which has been conducting a regional, cross-border survey of elephant populations in southern Africa over the past few months.

One day of the meeting was devoted to assisting the National Parks Board of South Africa in reviewing its elephant management policy for Kruger National Park. Extensive public criticism, both local and international, of Kruger's elephant culling policy, has inevitably put pressure on the Parks Board to review its management policy for the Park which harbours over 80% of South Africa's elephants.

Parks Board staff reviewed the history of Kruger and the development of its longstanding management policy. Other invited speakers presented overview papers which provided a strong conceptual backdrop to the subsequent discussions. The speakers also contributed insights into measuring the impact of elephants on biodiversity, defining "preferred management densities" within protected areas and

understanding the individual and synergistic effects of fire, elephants, artificial water and rainfall on vegetation dynamics. Discussions continued throughout the day on the role of research and its interface with management in formulating, adapting and implementing Kruger's policy into the future. We certainly hope that in accordance with its mandate to provide sound technical advice, the AfESG contributed in a meaningful way to the Parks Board's decision-making process which is still underway as we go to press.

Another day was taken up with working groups on five key topics: poaching and the ivory trade; habitat loss; local elephant overpopulation; human-elephant conflict and status of elephant populations. These discussions were held to provide active Group input to the development of a draft document consolidating ideas on priorities for elephant conservation in Africa. Incorporating suggestions for change and improvement during and after the meeting, the document is now moving into a second draft. It is hoped that ultimately, this document will become a working paper of the AfESG and serve as a useful guide for elephant managers and policy makers across the continent.

Among other recommendations, the working group suggested the establishment of a taskforce on human-elephant conflict to collect and organise all available information on the subject and examine the problems and solutions associated with conflict further. The human-elephant conflict taskforce will be voluntarily headed by Richard Hoare, whose extensive, relevant expertise from his ongoing work in Zimbabwe will no doubt help the process along.

A plenary session on the options for elephant management inside and outside protected areas was followed by discussions in two working groups. The talks provided a framework for making decisions on management options of elephants in different environments, under different policies, with differing problems, particularly with reference to forest and savanna habitats.

Further technical discussions were held during the meeting on the new IUCN Red List Categories of Threat. Prior to the meeting, members had not reached a consensus about the categorisation of the African elephant according to the new criteria but after further explanation, debate and discussion, the Group agreed to list the African elephant as Endangered, based on criterion A. 1(b).

On February 9, the Group passed a resolution stating that the "AfESG notes with concern the increases in poaching in Garamba National Park which constitute a grave threat to the remaining rhinos and elephants, and encourage the government of Zaire and international donors to give the necessary support to deal with the situation".

Last, but by no means least, the report *Four Years After the Cites Ban: Illegal Killing of Elephants, Ivory Trade and Stockpiles* was discussed by the AfESG members on two different occasions during the week. The objective of these sessions was to allow the members to air their views on the report in light of widely publicised controversy both within and outside the Group and to come to a mutual understanding on the way forward. In summary, the members at the meeting agreed by consensus that the accidental omission of the standard IUCN disclaimer in the original report should be rectified in all remaining copies. It was further agreed that the AfESG affirmed the professional integrity of the authors and found the personal nature of some of the criticisms both unjust and unacceptable.

The highlights of the meeting, with a selection of full papers, will be published in *Pachyderm* 22.

The African Elephant Database (AED)

The updated *African Elephant Database 1955* (Said, Chunge, Thouless, Craig, Barnes and Dublin, 1995) was completed and distributed prior to the AfESG meeting. In general the response to the updated AED has been positive. The new method of categorising elephant estimates into Definite, Probable, Possible and Speculative groups has been viewed as an objective and comprehensive attempt to display data according to their quality. The AfESG has secured funds for an additional three-year period for the AED. The next phase, which will involve more analysis and predictive modelling, will begin in May 1996 under the co-ordination of a newly-appointed database manager at the facility in Nairobi. The collaboration between the AfESG and the United Nations Environment Programme/Global Resource Information Database has been a real bonus for the project and the close co-operation bodes well for the next phase.

New AfESG Office for West and Central Africa

The new AfESG office in Cameroon became a reality in October 1995 with the appointment of Lamine Sebogo, from Burkina Faso, as the Programme Officer. After a spell in the WWF project office in Douala, Lamine moved to Yaoundé where he has been kindly accommodated in an IUCN project office. Members in West and Central Africa are urged to liaise directly with Lamine and to assist the AfESG to prioritise issues of concern for African elephant conservation in their region.

Projects

In the last few months the AfESG has been able to provide financial support to two new projects: one in Eastern Africa, where funds will allow the continuation of long-term radiotracking of elephants in Laikipia District, Kenya, and one in West Africa, where support is being given to a cross-border survey of elephants in northern Ghana and southern Togo. Technical advice was also given on a number of proposals which were sent to the AfESG office in Nairobi. One of these, a proposal for a collaborative survey of the elephant population in north-western Ethiopia and southwestern Eritrea, has since been offered funding by a donor.

Donors

None of the AfESG activities - the meeting, the AED, the new office, support to individual research initiatives, *Pachyderm* or the successful day-to-day running of the Secretariat in Nairobi - would be possible without the generous support of our donors, namely the United States Fish and Wildlife Service, the European Commission, the World Wide Fund for Nature, the UK Department of Environment and the Sir Peter Scott Fund. We look forward to their continued support and to a productive year ahead.

Finally, as we move towards the end of another IUCN triennium, plans are well underway, in Gland and Chicago, for the next SSC meeting and the World Conservation Congress in Montreal, Canada, in October 1996. To allow the Secretariat to address your concerns and continue to move the AfESG forward in fulfilling its mandate, members are invited to send us their suggestions concerning future activities, functioning and direction of the AfESG in the next triennium.

RAPPORT DE LA PRESIDENTE: GROUPE DE SPECIALISTES DE L'ELEPHANT AFRICAIN

Holly T. Dublin

WWF Regional Office, PO Box 62440, Nairobi, Kenya

Réunion au Kruger

Du 4 au 11 février 1996, le groupe des Spécialistes de l'Éléphant Africain (GSEAf) a réuni ses membres au Parc National Kruger, en Afrique du Sud. Près de trois quarts des membres du Groupe étaient présents. Ce fut une réunion mémorable à plus d'un titre. Au point de vue technique, des membres venus de tout le continent ont présenté des mises à jour sur des sujets tels que les translocations d'éléphants, la prévention de l'attaque des récoltes par les éléphants, l'absence de défenses, la dynamique des populations d'éléphants de savane et de forêt, les résultats des nouvelles recherches, l'impact des éléphants sur les habitats et les progrès de la recherche sur la contraception chez les éléphants. On a expliqué au Groupe le statut actuel des stocks croissants d'ivoire sur le continent et les menaces que pose leur sécurité. Nous avons écouté avec un sentiment d'inquiétude et de frustration les rapports d'Afrique centrale au sujet de la reprise du braconnage et du trafic d'ivoire d'éléphant, de la législation et du système judiciaire inadéquats, accentués par une corruption massive et un manque désespéré des ressources nécessaires pour que le gouvernement lutte contre ces problèmes. D'autre part, nous avons entendu les récents succès emportés par le projet ELESMAF qui mène depuis quelques mois une étude régionale, transfrontalière, des populations d'éléphants en Afrique australe.

La réunion a consacré une journée à aider l'administration des Parcs Nationaux sudafricains à réviser sa politique de gestion des éléphants pour le Parc National Kruger. La critique très importante exprimée par le public tant local qu'international à l'encontre de la politique de culling au Kruger, a obligé l'administration des Parcs à revoir sa politique de gestion du parc qui contient environ 80% des éléphants d'Afrique du Sud.

Le personnel de l'administration des Parcs a revu l'historique et l'évolution de sa politique de gestion. D'autres orateurs invités ont présenté des articles généraux qui ont pu constituer une base solide pour

les discussions qui ont suivi. Les orateurs ont aussi donné des aperçus sur les mesures de l'impact des éléphants sur la biodiversité, définissant les "densités préférentielles de gestion" à l'intérieur des aires protégées, compte tenu des effets individuels et synergiques des feux, des éléphants, de l'apport artificiel d'eau et des chutes de pluie sur la dynamique de la végétation. Les discussions se sont poursuivies toute la journée, sur le rôle de la recherche et de son interface avec la gestion, dans la formulation, l'adaptation et l'application de la politique du Kruger dans le futur. Nous espérons bien sûr qu'en accord avec sa mission de fournir des conseils techniques judicieux, le GSEM a pu contribuer de façon positive au processus de prise de décision de l'administration des Parcs qui est encore en cours au moment où nous mettons sous presse.

Les groupes de travail ont consacré une autre journée à cinq domaines clés: le braconnage et le trafic d'ivoire, la perte d'habitat, la surpopulation locale des éléphants, les conflits hommes-éléphants et le statut des populations d'éléphants. Ces discussions devaient fournir un support actif du Groupe à la mise au point d'un projet de document, en renforçant le choix des priorités pour la conservation des éléphants en Afrique. En y incorporant les changements et les améliorations suggérées au cours de la réunion et après, ce document constituera bientôt un second avant-projet. On espère qu'il deviendra finalement un document de travail du GSEAF et servira utilement aux gestionnaires et aux preneurs de décisions pour les éléphants de tout le continent.

Parmi ses recommandations, le groupe de travail a suggéré la création d'un organe chargé de récolter les données sur les conflits hommes-éléphants, de rassembler toutes les informations sur ce sujet et d'examiner en profondeur les problèmes et les solutions associés à ces conflits. Cet organe chargé des problèmes de conflits sera dirigé, à sa demande, par Richard Hoare dont la vaste expérience en ce domaine, acquise en travaillant au Zimbabwe, sera certainement très précieuse.

Les points forts de la réunion, ainsi qu'une sélection d'articles, seront publiés dans le numéro 22 de *Pachyderm*.

Une session plénière sur les différentes options en matière de gestion des éléphants, à l'intérieur et à l'extérieur des aires protégées, a été suivie de discussions dans deux groupes de travail. Elles ont apporté un cadre pour la prise de décisions quant aux options de gestion des éléphants dans différents environnements, avec des politiques différentes, des problèmes différents, spécialement en ce qui concerne les habitats de savane et de forêt.

Il y eut aussi pendant la réunion des discussions techniques sur les nouvelles catégories de la Liste Rouge des menaces dressée par l'UICN. Avant la réunion, les membres n'avaient pas atteint un consensus au sujet du classement de l'éléphant africain suivant les nouveaux critères mais, après de plus amples explications, un débat et des discussions, le Groupe s'est mis d'accord pour classer l'éléphant africain comme espèce en danger selon le critère A.I(b).

Le 9 février, le Groupe passa une résolution déclarant que le "GSEAF note avec inquiétude l'augmentation du braconnage au Parc National de la Garamba qui constitue une grave menace pour les derniers rhinos et les éléphants, et encourage le gouvernement du Zaïre et les donateurs internationaux de fournir le support nécessaire pour faire face à cette situation".

Enfin, et ce n'était pas le moins important, les membres du GSEAF ont discuté du rapport *Quatre ans après / interdiction par la CITES: la Massacre Illégal des Eléphants, le Trafic et les Stocks d'Ivoire*, à deux reprises pendant la semaine. Le but de ces sessions était de permettre aux membres du GSEAF d'exprimer leur point de vue sur le rapport face à la controverse largement publiée tant à l'intérieur qu'en dehors du Groupe et d'arriver à une entente mutuelle pour aller de l'avant. En résumé, les membres présents à la réunion ont accepté par consensus de rectifier dans toutes les copies restantes l'omission accidentelle de la "négation" standard de l'UICN dans le rapport original. Le GSEAF s'est aussi accordé à réaffirmer l'intégrité professionnelle des auteurs et à trouver que la nature personnelle de certaines critiques était aussi injuste qu'inacceptable.

La Banque de Données sur l'éléphant Africain (BDEA)

La Banque de Données sur l'Eléphant Africain 1995 (Said, Chungue, Thouless, Craig, Barnes et Dublin, 1995) remise à jour, a été complétée et distribuée avant la réunion du GSEAF. En général, elle a reçu une réponse positive. La nouvelle méthode de classification des estimations d'éléphants, répartie entre Certain, Probable, Possible et Spéculative, a été considérée comme une tentative objective et complète de présenter les données en fonction de leur qualité. Le GSEAF s'est assuré le financement de la BDEA pour trois années supplémentaires. La prochaine étape, qui peut impliquer plus d'analyses et de modèles de prédiction, commencera en mai 1996 sous la coordination d'un nouveau gestionnaire de la banque de données basé au bureau de Nairobi. La collaboration entre le GSEAF et la Banque de Données des Informations sur les Ressources mondiales du Programme des Nations unies pour l'Environnement est un avantage certain pour le projet, et la collaboration étroite augure bien de la phase suivante.

Nouveau Bureau du GSEAF pour l'Afrique Occidentale et Centrale

Le nouveau bureau du GSEAF au Cameroun est devenu une réalité en octobre 1995, avec la nomination de Lamine Sebogo, du Burkina Faso, au poste de responsable du programme. Après un passage au bureau du projet WWF à Douala, Lamine est parti à Yaoundé où il a été bien accueilli dans un bureau du projet UICN. Les membres d'Afrique occidentale et centrale sont priés de se mettre en rapport directement avec Lamine et d'aider le GSEAF à classer par ordre de priorité les sujets de préoccupation concernant la conservation de l'éléphant d'Afrique dans leur région.

Projets

Au cours des derniers mois, le GSEAF a pu fournir un support financier à deux nouveaux projets: un en Afrique de l'Est où l'argent va permettre la poursuite du *radiotracking* à long terme des éléphants du district de Laikipia, au Kenya, et l'autre en Afrique de l'Ouest, où un financement est attribué à une étude transfrontière des éléphants du nord du Ghana et du sud de Togo. Il a aussi pu donner des conseils techniques pour un certain nombre de propositions qui avaient été envoyées au bureau du GSEAF à

Nairobi. Parmi elles, une proposition pour une recherche commune sur la population d'éléphants du nord-ouest de l'Éthiopie et du sud-ouest de l'Érythrée s'est vu depuis offrir un financement par un donateur.

Donateurs

Aucune des activités du GSEAF - la réunion, la BDEA, le nouveau bureau, le support aux initiatives individuelles de recherche, *Pachyderm*, ou le bon fonctionnement quotidien du Secrétariat à Nairobi - ne serait possible sans le soutien généreux de nos donateurs, à savoir le Département Américain de la Pêche et de la Faune sauvage, la Commission Européenne, le Fonds mondial pour la nature, le

Département Britannique de l'Environnement et la Fondation Sir Peter Scott. Nous espérons que nous continuerons à recevoir leur support et que l'année qui vient sera productive.

Enfin, comme nous nous approchons de la fin d'un autre terme de trois ans pour l'UICN, les projets sont déjà bien avancés à Gland et à Chicago, pour la prochaine réunion de la CSE et le Congrès mondial pour la conservation qui aura lieu à Montréal, au Canada en octobre 1996. Pour permettre au Secrétariat de traiter vos sujets de préoccupation et de continuer à faire progresser le GSEAF vers ses objectifs, les membres sont invités à nous envoyer leurs suggestions pour les activités futures, pour le fonctionnement et la direction du GSEAF au long des trois prochaines années.

Photo credit: Rick Weyerhaeuser. WWF Photolibrary. Gland, Switzerland

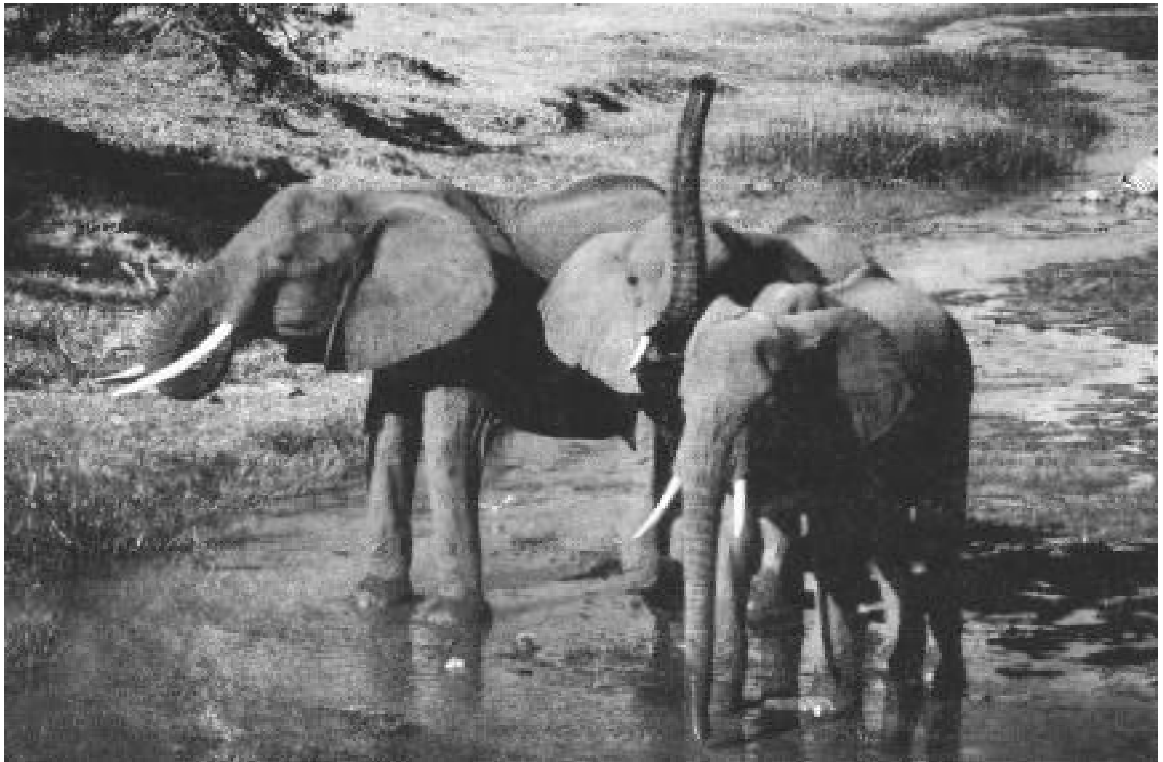

LETTER TO THE EDITOR

African elephants and European rabbits: a spurious correlation?

Dear Editor,

In June 1995 I moved to a new address, my move coinciding with the worst drought in Britain since the 1970s. My new property was overrun with rabbits (*Oryctolagus cuniculus*) and I observed, as the drought progressed, that they gnawed the bark of not the healthy trees and woody shrubs, but those in the process of dying from drought, or showing signs of drought stress. The death of many shrubs was hastened in this way and even highly aromatic species of evergreen conifers were attacked. The rabbits also concentrated upon newly transplanted species, which are presumably stressed.

We know that plant defences, in the form of phenols, are actively concentrated in bark. When a plant is stressed, the phenols are either quickly taken up by the leaves, or they, or some of them, break down. It seems that the decline in phenol concentration in the bark is detected by the rabbits by scent, the rabbits presumably finding the bark of a stressed plant more attractive due to a lowered phenol content.

A parallel may exist, therefore, between the behaviour of the European rabbits in my garden, and elephants in Africa. The latter appear to cause more tree damage in drought, and to concentrate on weak or dying trees,

hastening a process of decline which in many instances is already underway, e.g. when the water table is falling, or in the case of Amboseli in Kenya, when salinity is increasing. In some areas of Africa, bark stripping is most noticeable at the onset of the rains; this apparent contradiction may not be because the bark is rich in sap, as I stated in my recent book (Spinage, 1994) quoting conventional wisdom, but because the phenol concentrations in the bark are low at this time in species such as *Acacia*, for which the periods of blossoming and leaf emergence are in the dry season.

The answer, then, as to why elephants debark trees, might be that the levels of phenols in the bark have declined either through stress or the seasonal cycle of growth, making the bark more attractive to eat.

Yours sincerely,

Dr. Clive A. Spinage
Wickwood House
Stanford Road
Faringdon
Oxon SN7 8EZ
United Kingdom

Spinage, C. A. (1994) *Elephants*.
T & A.D. Poyser Natural History.
London.

THE SUMATRAN RHINO IN WAY KAMBAS NATIONAL PARK, SUMATRA, INDONESIA

Dwiatmo Siswomartono¹, Suherti Reddy², Widodo Ramono¹,
Jansen Manansang³, Ron Tilson⁴, Neil Franklin⁵ and Tom Foose⁶

¹Directorate General of Forest Conservation and Nature Conservation (PHPA), Ministry of Forestry, Manggala Wanbakti, Jalan Gatot Subroto, Jakarta 10270, Indonesia

² Sub BKSDA Way Kambas, Jalan Raya Labuan Ratu Lama, Wayjepara, Lampung Tengah, Indonesia

³Indonesia Centre for Reproduction of Endangered Wildlife, Taman Safari Indonesia, Cisarua, Bogor, Indonesia

⁴Department of Conservation, Minnesota Zoological Garden, Apple Valley, MN 55124, USA

⁵WayKambas Sumatran Tiger Project, Secretariat for Sumatran Tiger Project, Taman Safari Indonesia, Cisarua, Bogor, Indonesia

⁶IUCN/SSC Asian Rhino Specialist Group & International Rhino Foundation, 14000 International Road, Cumberland, OH 43732, USA

Photo credit: Ron Tilson and Neil Franklin



A Sumatran rhino in the wild, photographed with an infrared camera trap in Way Kambas National Park, Sumatra, Indonesia.

The Sumatran rhinoceros (*Dicerorhinus sumatrensis*) is probably the most critically endangered species of rhino. Perhaps as few as 400 survive. Approximately 200-250 of them occur on Sumatra in perhaps 10 localities, of which three are considered to harbour the major rhino concentrations: Gunung Leuser National Park, Kerinci Seblat National Park and Bukit Barisan Selatan National Park. Remnant populations are suspected to occur in other areas. A population and habitat viability assessment (PHVA) workshop in 1993 revealed that the rhino population in Sumatra was only 50% of previous estimates.

The Directorate General of Forest Protection and Nature Conservation (PHPA) in Indonesia is conducting an intensive programme for in situ protection through development and deployment of anti-poaching teams. The initial, catalytic funds for this programme are being provided by a grant from the Global Environment Fund (GEF) through the United Nations Development Programme (UNDP). This GEF project arose out of the United Nations Environment Programme (UNEP) Conference on Financing Rhinoceros Conservation in 1992 and again in 1993. The Asian Rhino Specialist Group has facilitated the GEF Project.

Until five years ago, the Sumatran rhino was believed to be extinct in Way Kambas National Park. However, reports suggested that rhinos might still occur in the area. In the earliest reports, it was unclear if the species was Sumatran or Javan. However, the size of some of the tracks indicated that it was the Sumatran species. The possibility of the Sumatran rhino still occurring in Way Kambas was discussed at the 1993 PHVA workshop. Its occurrence has now been unequivocally confirmed.

Colour photographs of the Sumatran rhino in the wild are even rarer than the species itself. The photograph accompanying this article was collected by an infrared camera trap, which is used in the Sumatran Tiger Project in Way Kambas National Park. The Tiger Project is a collaborative project with PHPA and Taman Safari Indonesia.

Way Kambas is also the site of a proposed Sumatran Rhino Sanctuary (SRS), which is currently defined in the Asian rhino conservation community as a managed breeding centre in native habitat*. Despite great expectations and efforts, the captive breeding programme for Sumatran rhinos, which commenced in 1984, has not been successful. A total of 40 rhinos have been captured in three areas where independent projects have been conducted: Indonesia (in cooperation with zoological organisations from the United Kingdom and United States), Peninsula Malaysia and Sabah. A major problem is believed to be the unnatural conditions which are provided by the captive programmes i.e. in terms of diet, climate (especially exposure to excessive sunlight and its ultraviolet component), size and complexity of enclosures, and social configuration of the rhino. As a consequence, the concept of re-orientating the captive programmes into managed breeding centres in a native habitat was developed through a series of meetings in Indonesia with PHPA. These "sanctuaries" will provide much larger enclosures and more natural conditions for the rhinos. The centres will be populated by rhinos which have been repatriated to native habitat from captivity. The SRS Programme is a collaborative effort of PHPA, Taman Safari Indonesia, Yayasan MISTRA Rhino and the International Rhino Foundation.

The Way Kambas Tiger Project is financially supported by Esso-UK and the Save the Tiger Fund (a joint venture between Exxon and the US National Fish and Wildlife Foundation). Financial support for the Indonesian Sumatran Rhino in situ protection programme is being provided by the GEF through UNDP with advice from UNEP. Funds for the Sumatran rhino Sanctuary in Way Kambas are being provided by the International Rhino Foundation.

*The usage of the term "sanctuary" is slightly different in the South East Asian context than in the context of African conservation. However, it is the objective for the managed breeding centres in Asia to evolve towards the African models.

THE SUMATRAN RHINOCEROS IN KALIMANTAN, INDONESIA: ITS POSSIBLE DISTRIBUTION AND CONSERVATION PROSPECTS

Erik Meijaard

The International MOF Tropenbos Kalimantan Project, PO Box 319, 76103 Balikpapan, KalTim, Indonesia

INTRODUCTION

The Bornean rhinoceros (*Dicerorhinus sumatrensis harrissoni*) is considered to be a subspecies of the two-horned Sumatran rhinoceros (Groves, 1965). Compared to the Sumatran rhinoceros of Sumatra and the Asian mainland, its teeth are smaller and its skull has slightly different proportions. The animal is also believed to be smaller and generally has longer hair (Nico van Strien, 1985; and pers. comm.).

The range of the Sumatran rhinoceros is rapidly decreasing, as hunting and the disappearance of suitable habitat have brought the species to the brink of extinction in many parts of its former range. In 1993 the total world population of the Sumatran rhinoceros was estimated at between about 400 to 550 individuals, most of them living in Indonesia and Malaysia, with some possible survivors in Myanmar and Thailand (YMR, 1993). At present, the species is listed as "Endangered" on the IUCN Red Data List of Threatened Animals, meaning that it is "facing a very high probability of extinction in the wild in the immediate future" (Groombridge, 1993). As precarious as the situation is for the mainland and Sumatran form of the Sumatran rhinoceros, the situation for the Bornean subspecies seems to be even more serious. The rhino has vanished from most of the island of Borneo, and there are virtually no populations left in the reserves.

DISTRIBUTION IN KALIMANTAN

Since 1840 the rhinoceros was known to inhabit Borneo, but agreement about its specific identity was not reached until 1895 (Rookmaaker, 1977a). It appears from historic data that, until relatively recent times, the Sumatran rhinoceros was widely spread throughout Borneo. Rookmaaker (1977b) provides a map with the rhino's approximate range in 1850, which shows that the species was still present in Borneo, except in: 1) the coastal area of northern Sarawak, 2) the Sangkulirang peninsula in what is now East-Kalimantan, 3) the southern part of what is now Central-Kalimantan,

roughly between Banjarmasin and Kotawaringin, 4) in West-Kalimantan north of the Kapuas River, or just south of it in the lower part of its course and 5) in southern Sarawak. Within the next hundred years, until approximately 1940, the Sumatran rhinoceros disappeared from most of the lowland areas of West, Central, South and East-Kalimantan.

After the surveys and literature searches which were conducted in the 1930s by Zondag (1931), Westermann (1939) and Witkamp (1932), rhino data in the scientific literature from Kalimantan became scarce. This paucity of new data was generally interpreted as a sign that the Kalimantan population had all but disappeared. Rookmaaker (1977b) stated that "I am confident that some individuals survive in Kalimantan, but probably not more than five... A few wandering individuals, or tiny remnant populations, may still occur in the upper reaches of the Mahakam, Kayan and Bahau Rivers, and in northern East-Kalimantan. More information does not exist".

However, now and then, reports of sightings or signs of rhinos have appeared in survey reports or newspaper articles. Pfeffer (1958), for instance, reported the tracks of two animals in the mountainous parts of East-Kalimantan. Van der Zon (1977) and Cockburn and Sumardja (1978) reported tracks in the Banamuda area in East-Kalimantan. However, after a survey was conducted in the latter area in 1980 and no signs of rhinos were found, it was concluded that there was no viable rhino population. Further rhino sightings were reported in the Nunukan area in 1975, around Muara Teweh in 1978; and in 1981-1982, it was also reported that Sarawak hunters regularly crossed the border with Indonesia to hunt rhinos in the upper Kayan or upper Mahakam area (van Strien, 1985). Van Strien (1985) stated, based on this information, that "these reports indicate that there might be rhinos left in some forgotten corners of this vast island. If the rumours are true there might be a few rhinos left along the Kalimantan - Sarawak border, probably in upper Kayan or upper Mahakam. This needs confirmation, but the chances

that a viable population can be found in the Indonesian part of Borneo are extremely slim. The rhino is probably not extinct, but very rare”.

Probably due to a combination of this gloomy outlook for long-term conservation of the rhino in Kalimantan, limited financial means for conservation work and an extensive potential distribution range for the last surviving rhinos, no further surveys were conducted to elucidate the present conservation status of the Sumatran rhinoceros in Kalimantan.

In 1994, a survey was initiated to investigate the present distribution range of the Bornean orang utan (*Pongo pygmaeus pygmaeus*) in Kalimantan. This survey was conducted in co-operation with the Ministry of Forestry (MOF) Tropenbos Kalimantan Project, based in East-Kalimantan. As this survey was going to cover potential rhinoceros habitat in Kalimantan, it was decided to include the gathering of information on recent sightings of rhinoceros in the orang utan survey. A budget for this was provided by the van Tienhoven Foundation in the Netherlands.

This paper will provide the anecdotal reports of rhino sightings in Kalimantan, as they were recorded during the above mentioned orang utan surveys.

METHODS

The information on absence and presence of both the orang utan and the Sumatran rhinoceros has been collected in an indirect manner. Firstly, the available literature was studied, both historic and recent, on rhino distribution. This included all available recent Environmental Impact Assessment (EIA) reports of logging concessionaries and the Department of Transmigration, as well as research reports from a wide variety of exploratory sectors. Secondly, experienced field workers from a number of research projects in Kalimantan were contacted to ask about their knowledge of recent rhino sightings. Last, and perhaps most important, field surveys were undertaken in Kalimantan. The 1994/1995 surveys were executed by Meijaard, in co-operation with the Directorate General of Forest Protection and Nature Conservation (DG PHPA) of the Ministry of Forestry of the Republic of Indonesia.

Because of the wide variety of sources, it must be realised that the incoming information may have been of varying accuracy. Consequently, the information was interpreted as absence or presence only. In addition, the sources of information were divided into

classes, and the information evaluated in relation to a supposed reliability of presence statements by each class.

These reliability classes were differentiated as follows:

1.00: Actual sightings of rhinos, their tracks or other clear signs of their presence, by the author.

0.75: Sightings of rhinos, their tracks or other clear signs of their presence, reported in the literature.

0.50: First-hand information on the sightings of rhinos by persons other than the authors (mainly local people interviewed during the surveys).

0.25: Second-hand information on the sightings of rhinos, either directly reported to the authors or reported in literature.

All individual presence reports were recorded and duly supplemented with data on the source of information, the longitude and latitude of the location, the name of the location, the date of reported sighting, the estimated value of reliability and the numbers of rhinos sighted. In some cases it was impossible to provide the exact geographical location of a rhino sighting, when for instance a relatively large area was mentioned. In that case the approximate central point of the area was used as the geographical location of the sighting. The value of geographical accuracy (A) indicates how far the actual geographical location of the sighting may be located from the point provided in the text, as follows:

- 1: between 0 and 20km
- 2: between 20 and 50km
- 3: between 50 and 100km.

Nonetheless the resulting interpretations are not more than a very generalised indication of absence or presence of a rhino in a particular area varying between a few hundred to tens of thousands of hectares of rainforest. For the present objective, i.e. to obtain a quick, general overview of the whereabouts of remaining rhinos in order to prioritise action for survival of the species, such crudeness is considered tolerable. However, this coarse-grained picture should be refined once the priorities have been set and up-to-date information becomes available.

Information on the geographical extent of protected areas and the current forest cover is still crude (scale

1: 1,000,000). It was obtained from the World Conservation Monitoring Centre (WCMC), the DG PHPA, and the Tropical Ecosystem Environment Observation by Satellites (TREES) Project.

RESULTS

The estimated reliability of each report is expressed by the value of reliability (R), while A is a measure

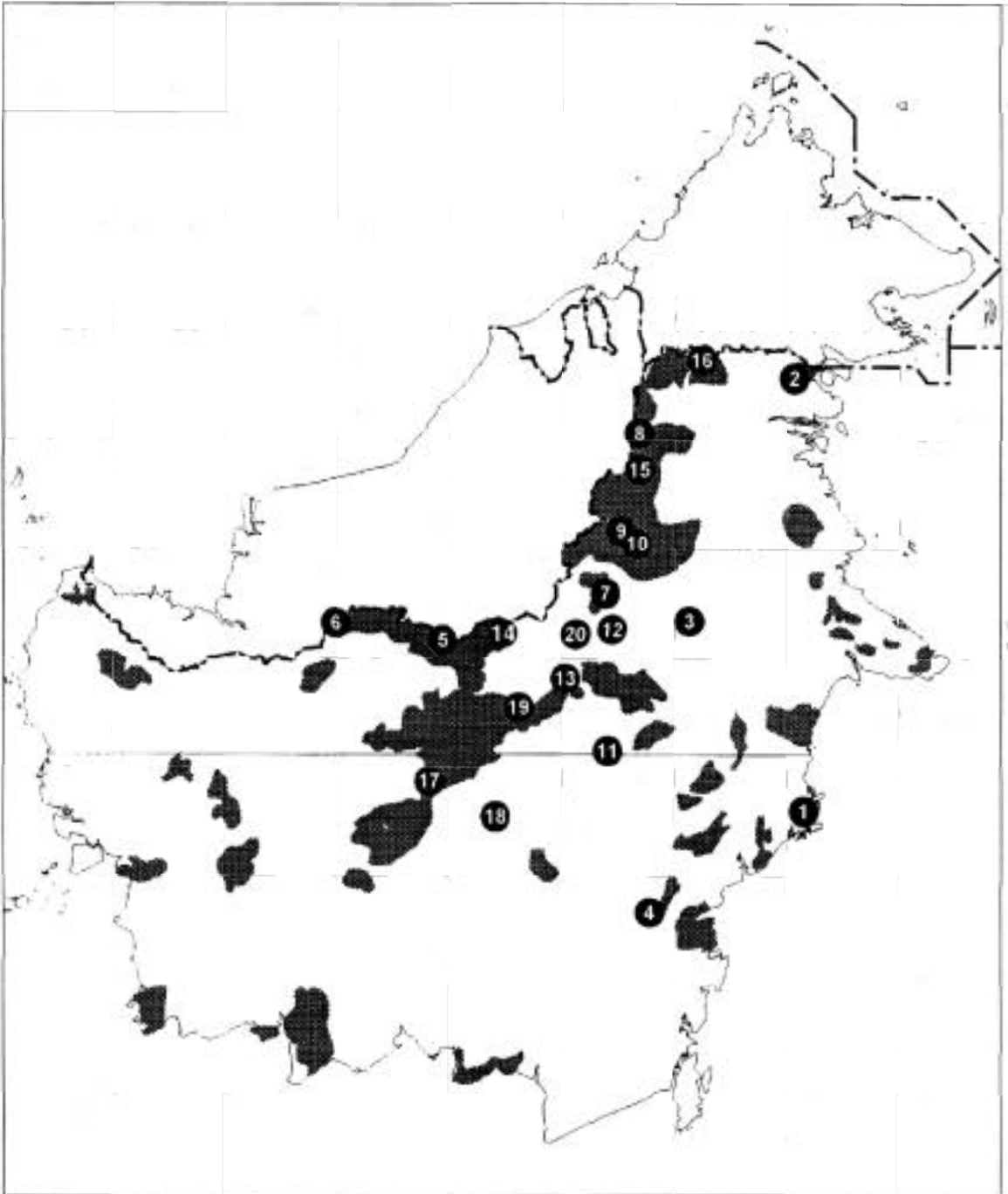

A map of Kalimantan in Indonesia, showing the sites of rhino presence reports. The shaded areas represent the proposed and existing protected areas in Kalimantan.

for the geographical accuracy of a reported sighting. The author saw no rhinos or signs of rhinos, so none of the reports were classed as R= 1.00. The map shows an overlay of the rhino presence reports and the proposed and existing protected areas in Kalimantan. The numbers on the map refer to the rhino sightings listed below in the text.

1) Samarinda

An informant at the board of tourism heard of a rhino sighting by people in Kutai Lama (E 117.42 S 0.62) in 1993. The informant went to check it in the village, but could not verify the sighting. If information is correct there might be one or a few rhinos left in the swamp-mangrove area east of Samarinda.

R=0.25, A= 1

2) Sungai Sebuku

During a survey around the S. Sebuku (E 117.31 N 4.04) in 1994 the informants from "Plasma", a nature conservation NGO in Samarinda, East-Kalimantan, were told of encounters with elephants and very occasional ones with rhinos. The informants were also told that around S. Sebuku, Kecamatan Nunukan, rhinos were still reported by logging concessions in 1980.

R= 0.25,A= 2

3) Gunung Belayan

On his rhinoceros distribution map, Yasuma (1994) indicates one location of "information of inhabitation from hearing" at ± 20km north of Gunung Kong Botak (E 116.17 N 1.42).

R=0.25, A= 1

4) Meratus Mountains

Rhino droppings and tracks were found by an Australian geologist on a recent survey in the Meratus area (E 115.74 S 1.72). The informant used to work for the PT Kelian Equatorial Mining and accompanies gold explorations. Unfortunately, so far it has not been possible to substantiate this information further.

R= 0.25, A= 3

5) Bentuang Karimun Nature Reserve

An employee of the Agency for the Conservation of Natural Resources (SB KSDA) in Pontianak, West-Kalimantan, heard rumours from local people in the Bentuang Karimun Nature Reserve (E 113.47 N 1.22) that there were still rhinos around. Further affirmative information on rhino presence in the Bentuang Karimun Reserve came from employees of the provincial Department of Forestry (Kanwil Kehutanan) in Putussibau, upper Kapuas.

R= 0.25, A= 3.

6) Bentuang Karimun Nature Reserve

Tasker (1994) reported that "on the Kalimantan side (of Lanjak Entimau) (E 112.30 N 1.40), the rare Sumatran rhinoceros has been seen". It is unclear what the original source of information was.

R= 0.25, A= 2.

7) 5. Irun, south-east of the Apo Kayan area

In the Ulu S. Irun (E 115.25 N 1.72) rhinoceros droppings of one animal were found in 1995 by a WWF fieldworker. According to the local people in that area rhinos were occasionally encountered, and also in the same area an army helicopter pilot claimed to have seen a rhino on a river bank.

R=0.75, A= 1

8) Upper S. Bahau

On the border between Indonesia and Malaysia, Indonesian army field surveyors saw tracks of rhinos in the area up from Ulu Bahau (E 115.62 N 3.45). Elephants were also reported to occur in this area.

R = 0.25, A= 2

9) Ulu S. Iwan in Apo Kayan

In the area between Ulu S. Punjungan, Ulu S. Iwan and Ulu S. Lurah (E 115.48 N 2.38) the "sightings" of three rhinos, or their signs (it is unclear if animals were actually seen), were reported by "geharu" (*Aquilaria malaccensis*) collectors.

R=0.25, A=2

10) S. Kat

Rhino tracks were found between the headwaters of S. Punjungan and S. Kat. (E 115.58 N 2.27) close to Apau Napu in 1988. Informants were pretty sure that footprints were made by a mother and calf.

R= 0.25, A= 2

11) Bkt. Buringajok

In 1985, a rhinoceros was killed in the Bkt. Buringajok area (E 115.28 N 0.03) close to the border between Central and East-Kalimantan. According to the informant, a Dayak from Damai in the Melak region, rhinos are not hunted anymore now that there is a law against this. It is unclear if rhinos still exist in this area.

R= 0.25, A= 1

12) S. Boh, close to Kubu Long Bakung

The informant himself saw one poached rhinoceros around S. Boh (E 115.33 N 1.33) (tributary of S. Mahakam) and he saw tracks of two rhinos, in the years between 1969 and 1972.

R = 0.50, A = 2

13) G. Bntuajau, East-Kalimantan

In 1986 the informant from the Dayak Uma tribe in Batu Majang (Long Bagun), clearly identified rhino tracks and droppings in a pass between lime stone rocks on G. Batuajau (E 114.82 N 0.80).

R=0.50, A= 1

14) Upper Kapuas, West-Kalimantan

Several accounts were collected from people in Putussibau, upper Kapuas, West-Kalimantan (E 114.00 N 1.25), as follows:

Rhinos are possibly still present in the Ulu Kapuas area; in the mountains upstream from Putussibau “geharu” collectors sometimes see their tracks. They are still being hunted for the medicinal and ornamental value of their horns.

In the 1950s and 1960s, there were several Chinese and Dayak people who were specialised rhino hunters. Several rhinos were shot in the vicinity of Putussibau. Now people never, or hardly ever, go out to look for rhinos.

In the 1960s and 1970s, people from the Ulu Kapuas were still hunting rhinos in the mountains, but now they report that because rhino products cannot be sold anymore, they have stopped looking for them. Also as a result of other work in the area (logging, gold mining, bird nest collecting), people are less willing to spend months in the forest looking for rhinos.

R=0.25, A=3

15) Apau Ping

In the Ulu Bahau area (E 115.62 N 3.05) a WWF official was told of the presence of rhinos. No further information available.

R= 0.25, A= 2

16) Ulu Sembakung

A “few” rhinos were reported to exist in the Ulu Sembakung Nature Reserve (E 116.30 N 4.23) (YMR, 1994).

R = 0.75, A = 2

17) Ulu S. Ketiagan and Ulu S. Kahayna

Rhinos were supposed to be present in 1987 in the area east of Bukit Raya, between Ulu S. Ketingan and Ulu S. Kahayan (E 113.33 S 0.30). However, the story is rather vague with indirect information.

R = 0.25, A = 3

18) Ulu S. Barito km 30 PT Tunggal Pemennag (now PT KTC)

An informant saw foot prints the size of a food plate in 1984, which he assumed to be of the rhinoceros. He clearly described the shape and three toes that were visible in the print. (Location: E 114.05 S 0.68)

R= 0.50, A= 3

19) Dudson *et al.* (1990) reported the following: “Sumatran rhinoceros and banteng were both rumoured by local people to occur to the north-east of Barito Ulu (E 114.31 N 0.49). While these reports are best treated with extreme caution, it is worthwhile recording them, considering the critical global status of these species”.

R = 0.25, A = 3

20) S. Boh, S. Merasah (east of Long Pahangai)

A former inhabitant of this area (E 114.93 N 1.28) claimed that rhino tracks were quite often found there in 1969. However, he was not aware of reports of actual encounters with the rhinoceros.

R = 0.25, A = 4

DISCUSSION

The paucity of reported rhino sightings during this survey may be for two different reasons. First, the survey was designed for gathering information on the distribution patterns of orang utans, and not specifically for information on rhinos. While orang utan density generally declines precipitously with increasing altitude, rhinos now seem to be restricted to mountainous areas. This implies that a relatively large amount of survey time was spent away from potential rhino habitat, limiting the amount of information that could have been gathered. Second, rhinos are rare in Kalimantan and information on the abode of this elusive animal is hard to obtain. In addition, rhinos are still highly valued as an illegal hunting trophy in Kalimantan, and therefore people may be less enthusiastic about sharing information on the animals' whereabouts.

Kayan-Mentarang

The results of the survey indicate that the present rhino population is probably concentrated in and around the 1.6 million hectares of the Kayan-Mentarang Reserve in East-Kalimantan. Inside the Reserve there are probably two important areas:

- 1) the headwaters of the S. Bahau in the G. Latuk (1850m) and Bkt. Kalung (1724m) areas.
- 2) the Bkt. Tikung (1 804m) range in the upper reaches of the Kat, Iwan and Punjungan Rivers. The forest is relatively undisturbed, but "geharu" collectors are active in the area, which implies a potential threat to the population as these are often the people who track down the rhinos.

The Kayan-Mentarang Nature Reserve is currently the focus of a WWF community-based management project to review existing boundaries. MacKinnon (1988) remarked that "the Reserve, as gazetted, exists only on a map - no boundaries are marked on the ground and indeed, maps of the area are rather inadequate and often wrong. The long, thin shape of

the Reserve and its huge size make it impossible to manage, even if staff were to be sent into the field. Within the Reserve boundaries are numerous old settlements and "ladang" lands - these should be excised". He further stated that "the Kayan-Mentarang Reserve adjoins Pulong Tau in Sarawak and the Maliau basin in Sabah. The adjacent Maliau basin is still known to have a small resident population of rhinos, as does the adjoining Baram basin in Sarawak". MacKinnon did not find any direct evidence for the presence of rhinos in the Kayan-Mentarang Reserve.

Up until now the WWF project has not investigated the presence of rhinos in the Reserve. No extensive mammal surveys have yet been conducted, nor have there been any attempts to pin-point the remaining rhinos in the Reserve by indirect data collection. The reasons for this are twofold: WWF personnel do not believe that rhinos are present in the Kayan-Mentarang area because the rumours about rhinos are considered unreliable and secondly, if any rhinos exist within the Reserve, they suggest that it would be better to leave them alone because surveys would only draw the attention of rhino hunters. The second point should be carefully considered. Would a possible rhino population benefit from the increased attention generated by conservation attempts? How should these conservation attempts be directed in order to avoid negative effects?

The author still suggests that surveys be conducted in the two above-mentioned areas in the Kayan-Mentarang Reserve, in order to establish the present conservation status and survival chances of the remaining animals. This should be done as soon as possible, preferably in a secretive way and in cooperation with reliable people. The outcome of these surveys should indicate if there is a viable population and if so, what kind of future activities would be needed to improve its protection.

Bentuang Karimun

The presence of rhinos in the 600,000ha Bentuang Karimun Nature Reserve could not be substantiated as reports were contradictory. However, rhinos were hunted in the upper Kapuas area until quite recently. Furthermore, the Bentuang Karimun area is virtually uninhabited and recent satellite imagery shows that its forests are more or less untouched. The area is almost exclusively visited by "geharu" collectors who tend to penetrate into the most remote corners and are likely to track down any remaining rhinos. It is

interesting to note that professional hunting in the area apparently has stopped since the 1970s, because the density of the remaining animals became economically too low to sustain the hunters, and other more rewarding activities were developed. This may mean that hunting pressure for the remaining rhinos, if any, is currently low. The Bentuang Karimun Reserve is going to be part of a WWF management project from 1995 onwards.

S. Irun/G. Belayan/S. Boh

Four different sources mentioned the presence of rhinos in the area of G. Belayan, among which the reported finding of tracks and faeces in upper S. Irun was thought to be reliable. The S. Irun report came from the area of the proposed Apo Kayan Reserve. It is unclear if this population or individual is in any way connected to the rhinos which were reported around the very remote G. Belayan. The areas of S. Boh and S. Kayaniut on the west side of the G. Belayan complex are inaccessible because of the many rapids on the rivers and the quality of the (mostly heath) forest, which provides travelers with very few forest products. Consequently, the density of the human population is low with only a few villages in a large area.

Ulu Sembakung

The proposed 500,000ha Ulu Sembakung Nature Reserve was reported to contain Kalimantan's only wild populations of elephants and possibly rhinos (MacKinnon, 1981). YMR (1994) mentions that a few rhinos occur in this proposed reserve, but it is unclear which source of information has been used.

G. Meratus

The supposed sighting of rhino signs in the Meratus Mountains has not been substantiated and a request for further information has remained unanswered. The exact location of the sighting was a guess, because there is a mountain named G. Meratus and a mountain range named the Meratus Mountains. These two possible location sites could therefore be as far apart as 200km. Supposedly, there are photographs available of the reported tracks and faeces, but so far these have not been obtained.

Bkt. Batuajau/S. Murung

A few rhinos may still roam the mountains between Central and East-Kalimantan and also between Central and West-Kalimantan. Several reports of rhino

sightings came from this large area but none of the reports were very convincing. This large, mountainous area consists mostly of Protection Forest, and therefore threats of habitat destruction are negligible. However, a lot of people move through these forests in search of "geharu", edible swifts' nests and other forest products, which may constitute a potential threat to any surviving rhinos.

RECOMMENDED ACTIONS

- 1) Conduct initial small-scale rhino surveys in the following areas (which are listed in accordance to decreasing priority of action):
 - upper S. Bahau
 - upper reaches of the Kat, Punjungan and Iwan Rivers
 - Ulu Sembakung Nature Reserve
 - G. Belayan/S. Boh/S.Kayaniut
 - upper S. Irun
 - S.Sebuku area
 - the eastern part of Bentuang Karimun
 - G. Meratus
- 2) Based on the initial surveys, select the areas where the highest densities of rhinos are expected to occur, and conduct more detailed surveys in order to indicate local densities and distribution range. These surveys should use the standardised methods recommended by the IUCN/SSC Asian Rhino Specialist Group (Tom Foose, pers. comm.).
- 3) Decide whether there are enough rhinos in a population to withstand the combined effects of demographic, environmental and genetic chance events, based on Minimum Viable Population estimates.
- 4) Decide whether the *in situ* protection of the selected population of rhinos is feasible, and if so produce a management plan for implementing protective measures.
- 5) Take the necessary steps to provide long-term protection for the selected populations of rhinos.

CONCLUSIONS

Recent reported sightings indicate that the Sumatran rhino is still present in Kalimantan. Although the reports vary in accuracy and reliability, a cautious conclusion may be that since 1985 at least some 20 rhino sightings, including that of one young rhino,

have been reported in Kalimantan. The killing of a rhino was reported twice. The rhino sightings imply that the remaining animals are spread out over the most mountainous and remote areas of Kalimantan. The present distribution range of the Sumatran rhino in Kalimantan most likely includes the Ulu Bahau area and the southern region of the Kayan-Mentarang Nature Reserve, the Ulu Sembakung Reserve, the S. Sebuku area, possibly the Bentuang Karimun Reserve in the Upper Kapuas area, the area south of Kayan-Mentarang, towards Central-Kalimantan, the Ulu Barito, Ulu Kahayan and Ulu Ketingan areas in Central-Kalimantan and possibly the Meratus Mountains in East and South Kalimantan.

The author was surprised to find several indications of the presence of rhinos, and although some of them may be unreliable, more rhinos may remain in Kalimantan than was previously assumed. However, an optimistic attitude for the future of the rhino may be premature, because the remaining rhinos face an uncertain future with an expected increase in human encroachment, habitat perturbation and fragmentation. Unless some drastic measures for improved protection of the species are enforced, the disappearance of the last remaining rhinos of Kalimantan may just be a matter of time.

ACKNOWLEDGEMENTS

I gratefully acknowledge the Ministry of Forestry, in particular its Directorate General for Forest Protection and Nature Conservation, and the team leader of the MOF Tropenbos Programme in East-Kalimantan, Dr Willie Smits. I am indebted to our sponsors, namely the van Tienhoven Foundation, the World Wide Fund for Nature (WWF) Netherlands, the Lucie Burger Stichting, and the Golden Ark Foundation in the Netherlands. I am grateful for the support we received from several staff members at headquarters and provincial offices of the DG PHPA. Without their help in administrative matters, along with their support and advice concerning the surveying and the provision of staff to accompany us in the field, it would have been impossible to operate. I would especially like to thank Ms. Rona Dennis and Mr. Rencana Tarigan of the ODAIPHPA Remote Sensing/GIS Unit, for their invaluable assistance in the preparation of the maps. Finally, I would like to express my appreciation and thanks to all other people who were a valuable source of information on whereabouts of rhinos in Kalimantan, and to everyone who has assisted me in the execution of my work.

REFERENCES

- Cockburn, P.F. & Sumardja, E.A. (1978) World Wildlife Fund Project 1524. Kutai, Kalimantan, Indonesia.
- Dudson, G., Wilkinson, R. & Sheldon, B. (1991) The avifauna of Barito Ulu. Barito Ulu Project Report, Jakarta.
- Groombridge, B. (ed.), 1993. *1994 IUCN Red List of Threatened Animals*. IUCN Gland, Switzerland and Cambridge, UK.
- Groves, C.P. (1965) Description of a new subspecies of rhinoceros, from Borneo, *Didermocerus sumatrensis harrissoni*. *Sügetierk. Mitt.* 13,128-131.
- MacKinnon, J. & Mulia, B.A. (1981) *A National Conservation Plan for Indonesia Vol. V Kalimantan*. FO/INS/78/061, Field Report 18: FAO/UNDP National Parks Development Project, Direktorat Jenderal Perlindungan Hutan Dan Pelestarian Alam, Bogor.
- MacKinnon, J. & Warsito (1982) *Gunung Palung Reserve. Kalimantan Barat. Preliminary Management Plan*. UNDP/FAO Field Report.
- MacKinnon, K. (1988) Consultant's report of biodiversity specialist, for USAID PD) mission: natural resource management in Kalimantan. Unpublished.
- Pfeffer, P. (1958) Situation actuelle de quelques animaux menacés d'Indonesie. *Terre et Vie*, 05,128-145.
- Rookmaaker, L.C. (1977a) The rhinoceros of Borneo: a 19th century puzzle. *J. Malay. Brch. R. Asiat. Soc.* 50,52-62, pls. I - IV.
- Rookmaaker, L.C. (1977b) The distribution and status of the rhinoceros, *Dicerorhinus sumatrensis*, in Borneo - A Review. *Bijdr. Dierk.*, 47,197-204.
- Tasker, R. (1994) *Far Eastern Economic Review*, 8 December, 1994.
- Van Strien, N.J. (1985) *The Sumatran Rhinoceros - Dicerorhinus sumatrensis Fischer, 1814 - in the Gunung Leuser National Park, Sumatra, Indonesia; its Distribution, Ecology and Conservation*. Ph.D. thesis. Wageningen, the Netherlands.

Westermann, J.H. (1938) Natuur in Zuid- en Oost Borneo. In: 3 jaren Indisch Natuurleven, 11e jaarverslag (1936-1938). *Ned. Ind. Ver. tot Natuurbescherming*.

Witkamp, H. (1932) Het voorkomen van enige diersoorten in het landschap Koetai. *Trop. Natuur* 21,169-175.

Yasuma, S. (1994) An invitation to the mammals of East-Kalimantan. Tropical Rain Forest Research Project JTA-9(a)- 137. *Pusrehut Special Publication* No. 3 pp.384.

YMR (1993) *Conservation Strategy Rhinoceros Indonesia* (in Indonesian). Directorate General of Forest Protection and Nature Conservation of the Indonesian Ministry of Forestry and the Rhino Foundation (Yayasan Mitra Rhino).

Zon, A.P.M.v.d. (1977) Sumatran rhino in Kalimantan (Borneo). *Tigerpaper* 4, 12.

Zondag, J.L.P. (1931) Het voorkomen van eenige diersoorten in de Zuider - en Oosterafdeeling van Borneo. *Trop. Natuur* 20,221-223.

MATING SUMATRAN RHINOCEROS AT SEPILOK RHINO BREEDING CENTRE, SANDAKAN, SABAH, MALAYSIA

Edwin J. Bosi

Wildlife Department Sabah, WDT 200, 90009 Sandakan, Sabah, Malaysia

INTRODUCTION

The idea of capturing and breeding the rare Sumatran rhinoceros (*Dicerorhinus sumatrensis*) was conceived in the USA in the early 1980s and received considerable support, especially in view of the rapid turning of forest lands - the natural habitat of this species - into plantations. Although much original forest habitat is being lost, the Sumatran rhino survives even better in secondary forest and land where logging has occurred. Its main danger now is from poachers who continue to kill rhinos for their valuable horns, meat and bones. Rhinos are easy prey in areas which have been logged.

In 1985, the State Government of Sabah's Rhino and Wildlife Conservation Committee (SRWCC) established a local capture and breeding programme. The SWRCC undertook numerous ground surveys to ascertain the presence of rhinos, their home range and their safety. The capture programme was activated in 1987 and began with the capture of rhinos that were exposed to poachers due to the loss of their habitat.

CAPTURE PROGRAMME

The first rhino, an adult male, was captured at Linbar Kinabatangan on 25 March 1987. Unfortunately he died in the capture pit, due to internal injuries and respiratory failure, as seen in the Table below.

Table. The number of captures and the fate of each rhino in the capture programme.

No.	Date of capture	Sex	Remarks
1.	28.03.87	M	Caught at Linbar, Kinabatangan. Died in the pit due to internal injury and respiratory failure.
2.	14.07.87	M	Tenangang, died in Rhino Breeding Centre Sepilok (RBCS) in 1991.
3.	24.05.88	M	Died in the pit.
4.	22.04.89	F	Lumparai, mated on 28.10.95.
5.	05.05.91	M	Takala, died in RBCS on 08.05.95 due to tetanus.
6.	27.08.92	M	Sidom, mated with Lumparai and Gologob.
7.	05.06.93	M	Caught at Bulud, Sukau. Radio-tagged and released at Tabin Wildlife Reserve on 30.11.93. Located 30km from site of release recently.
8.	20.07.93	M	Tanjung
9.	17.06.94	F	Gologob, mated on 26.10.95
10.	22.11.95	M	Malbumi estate, Sukau Moved to RBCS on 25.11.95.

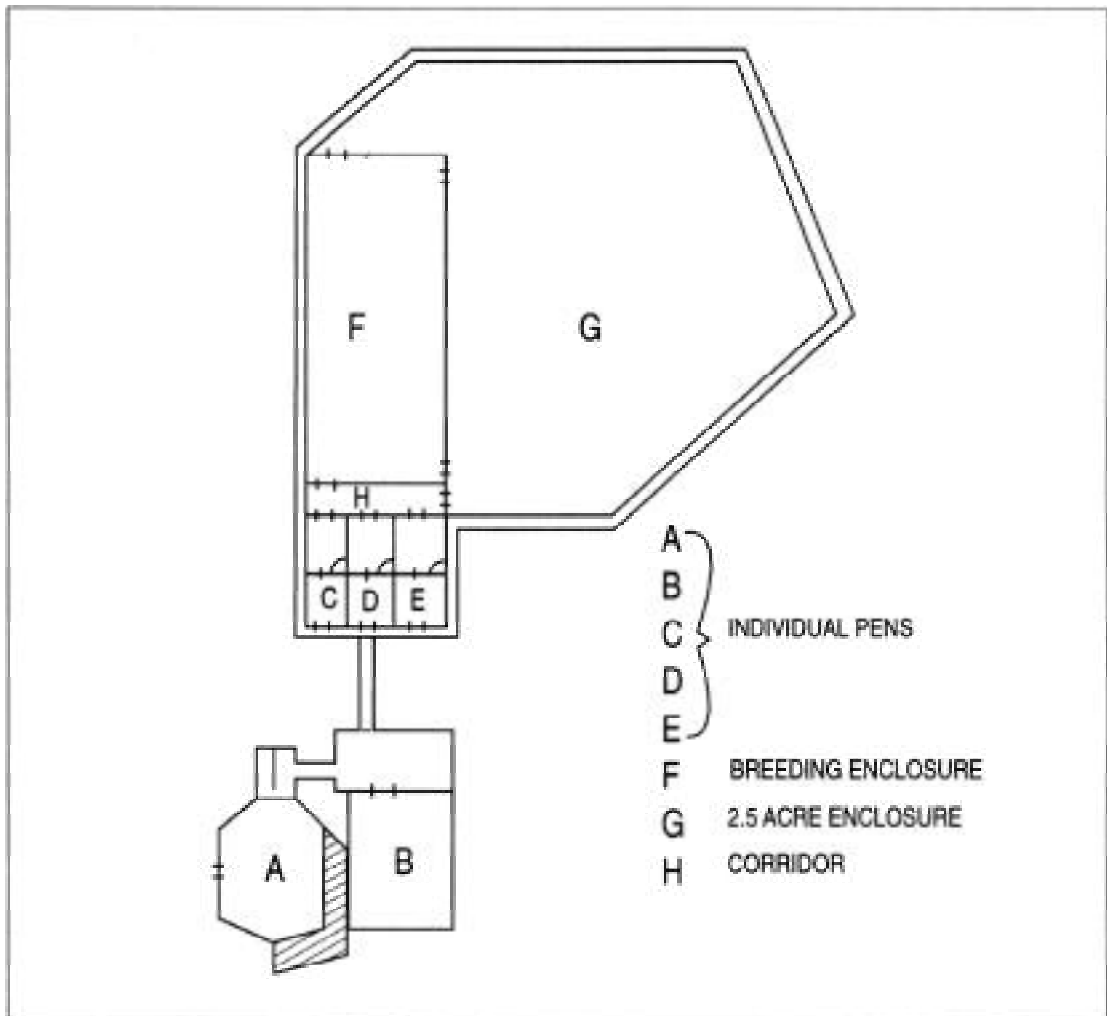

Figure. A diagram of the rhino stockade at the Rhino Breeding Centre, Sepilok.

The SRWCC, which evolved into a highly trained and efficient capture team, was absorbed into the Wildlife Department Sabah (WDS) when the latter, which was formally the Wildlife Unit of the Forestry Department Sabah, was elevated into a Department under the Ministry of Tourism and Environmental Development, Sabah, in 1988.

In March 1995, Sabah was allocated \$411,334 for a three-year rhino project under the sponsorship of the Global Environmental Facility (GEF) of the United Nations Development Programme (UNDP). This funding is mainly for the provision of facilities, manpower and technical support for the protection of this endangered species in situ. It incorporates minimal provision for captive breeding. The Wildlife Department, with the advice of Dr. Tom Foose and

Dr. Nico van Strein, decided to activate its own breeding programme in July 1995.

The Rhino Breeding Centre Sepilok (RBCS) currently has three males and two females. The facility is comprised of five individual stalls or pens, a breeding enclosure and a 2.5 acre enclosure. The walls are made from tropical hardwood ("belian"). A sketch of the facility is given in the Figure.

On 3 July 1995, a female, Gologob, was released into the 2.5 acre enclosure where 24 hour observations were conducted by a ranger, David Anthonius, assisted by Sillih Sikin, under the supervision of the author (a wildlife veterinarian). The observation team looked for signs of oestrus in the female rhino, such as a swollen vulva, mucoid discharge from the vagina and restlessness.

The 2.5 acre enclosure is part of the 4,300ha Sepilok Forest Reserve. It took less than two months for Gologob to “clear” the vegetation. She continued to be given green feeds daily, along with water and a salt lick. It was noted that an abrasion on her wither appeared to heal faster when covered with mud. She was not bothered by the presence of *Tabanus* flies.

On 3 August 1995, another female, Lumparai, who was kept in a pen, was observed to discharge clear mucous from her vagina. With this discovery, Lumparai was recruited into the study so that our observations now covered two females in different environments.

The observations were then extended to include the two males, Sidom and Tanjung. They were released into the breeding enclosure on a rotational, weekly basis. We were interested to note their reactions in the presence of Gologob. We noticed that each of them made lip contact and locked horns with Gologob at the common gate, and paced along the common wall. We also noticed that each male was excited, with his penis erect.

It was easier to note when the female was interested in the male. She would appear restless, moving around and making noises. She would stand near the gate or pace along the wall in order to look at the male on the other side. When she was lying on her side, a little manual manipulation of the vulva would reveal the clear mucous in her vagina.

Gologob

It was difficult to look for mucoid discharge in Gologob because of the mud cover and her activity near the wall. However, on two occasions we were able to see mucous in the vagina by manual manipulation to open the vulva when she was lying down on her side. Her vulva appeared swollen and soft. She was restless and would walk about more than usual when there was no male in sight. When the male was in the other enclosure, she would wait at the gate and pace along the wall.

Gologob came into oestrus on 31 July 1995, 28 August 1995 and 28 September 1995. Based on these dates, we estimated the oestrus cycle to be between 28 to 30 days. Therefore, we made plans to mate her on 27 October 1995. We moved Sidom into the breeding enclosure on 21 October 1995. On 25 October Gologob began to be restless but the male was not interested. He relaxed in the mud wallow most of the

time. On 26 October he began to show interest in Gologob by coming over to the gate and indulging in lip contact and horn-locking. We decided to open the gate for Gologob to enter the breeding enclosure at 15.15 hours and she headed straight for the male.

We let Gologob into the breeding enclosure again at about 11.00hrs on 29 October 1995 but there was no mutual interest shown between Sidom and Gologob. We decided that the breeding period was over and returned her to the enclosure.

Lumparai

On 3 August 1995, Lumparai was observed to have a mucoid, vaginal discharge. This was evident when she was lying on her side. Lumparai is a tame rhino, which made examination of her discharge relatively easy. She came into oestrus again on 28 September 1995. She was observed to urinate frequently around the stockade and to make more noises than usual. Her vulva was slightly swollen and soft.

On 26 October we moved Lumparai into the corridor where Sidom could see her. There was no mutual interest. On 27 October she was noticed to have a mucoid, vaginal discharge at 19.30hrs. We released her into the breeding enclosure during the morning of 28 October 1995 but there was no mutual interest with Sidom. She spent her time in the mud wallow while Sidom walked about. We put Sidom into the individual pen and returned him at 14.54 hours. This time Sidom went across and displaced Lumparai from the wallow. At 16.00hrs when he began to show interest in Lumparai and pursue her. There was a long courtship before he had the opportunity to mount her. We observed six mountings before it became dark. In the morning we noticed that Sidom was in the wallow while Lumparai had another wallow near the gate. We decided to return Lumparai to her pen at 09.00hrs on 29 October.

Lumparai was again observed to have a mucoid discharge from the vagina at 12.30hrs on 29 October. We decided to return her into the breeding enclosure, moving her into the corridor first. Tanjung, the second male, was in the breeding enclosure. We noticed that Tanjung was apprehensive when we moved him into the breeding enclosure. He was also “shivering” on the hindlegs when Lumparai expelled air from her lungs. Gradually they made lip contact and locked horns but were very aggressive. Lumparai lacked interest and she was returned to her pen after two hours in the corridor.

SUMMARY OF OBSERVATIONS OF MATING BEHAVIOUR

1. The oestrus cycle was estimated to be between 28 to 30 days.
2. During oestrus, the female was restless, with a swollen vulva and soft, clear, stringy mucoid discharge from the vagina. The vulva could remain swollen for five days. The discharge could be seen when the female was lying on her side. It was difficult to see the mucous when she was covered with mud but it was possible to see it when the vulva was opened manually.
3. The female was obviously interested in the male when she was in oestrus. The male would go to the common gate to make lip contact and to lock horns. The female would walk or pace along the wall, followed by the male on the other side.
4. The male was not interested in the female if she was not in oestrus.
5. Our experience with Lumparai indicates that mating is most likely to take place at least 20 hours after the mucoid discharge appears. This knowledge is useful for reducing the duration of courtship in capture.
6. We observed that mating occurred in late afternoon. Both mountings of Sidom, to Gologob and Lumparai, were accomplished after 15.00hrs.
7. The male only mounted when the female was quiet and still. When the site was not conducive to mounting, he pushed her gently from behind in order to move her where he wanted. He placed his lower jaw on her back and then lifted both front legs, one at a time. When there was stability he extended his penis, which became erect. He swung his penis towards the vaginal orifice, moving back slowly to avoid catching his penis between the female's thighs. During penetration, the two flaps remained flaccid.

Mounting lasted for up to eight minutes but the actual copulation took a maximum of about two minutes. There were thrusting movements of the hindquarters during copulation.
8. The male could be aggressive when pursuing the female. He could push or knock her hard on the abdomen until she ran away from him. In this situ-

ation the female and male had to be separated to avoid injuries.

9. The female in oestrus could tease the male by running for a short distance and looking back. If he pursued her, she would walk away. In some cases, when the male did not pursue her, she would return to him.

RECOMMENDATIONS FOR SUMATRAN RHINO BREEDING PROGRAMMES

1. Sumatran rhinos can be habituated to people. This makes oestrus detection easier.
2. Oestrus can be detected in a female by looking for three signs: swelling of the vulva, restlessness and mucous discharge. The detection of oestrous enables a planned release into the breeding enclosure with the male. Both male and female activities should be observed at the common gate and wall.
3. It is advisable to let the female into the male enclosure. She will seek out the male when she is in oestrus.
4. It is advisable to have a mud wallow in the breeding enclosure.
5. The breeding enclosure should have undulating topography for easier mating to occur.
6. It is advisable to keep the horns of the rhinos short to avoid accidents.
7. Tetanus is a threat to the Sumatran rhino. Any lameness seen after mating must be attended to.
8. It takes about two months for one rhino to clear one hectare of jungle with low vegetation. This is useful information for future planning of rhino enclosures.
9. It is necessary to ensure that there is ample space to facilitate contact between the male and female, to detect oestrus and to observe mating.

This paper was presented during the Malaysian Rhino PHVA Workshop from 27 to 28 November 1995 at the Renaissance Hotel, Sandakan, Sabah, Malaysia.

SMUGGLING ROUTES FOR WEST BENGAL'S RHINO HORN AND RECENT SUCCESSES IN CURBING POACHING

Esmond B. Martin

c/o WWF Regional Office, PO Box 62440, Nairobi, Kenya

Photographs by Esmond B. Martin

The greater one-horned rhino population in West Bengal is the second largest in India, after Assam. The rhino population in West Bengal declined significantly at the turn of the century, due to legal

hunting; and from 1969 until 1986, nearly all because of poaching. The population is now increasing due to improved conservation efforts (see Table).

Table. Estimates of West Bengal's rhinos, and numbers poached, 1930 to 1993.

Year	Number of rhinos in Jaldapara	Number of rhinos poached in Jaldapara	Number of rhinos in Gorumara	Number of rhinos poached in Gorumara	Total number of rhinos poached in West Bengal
1930/1		c.50			c.50
1932	40-50				
1936/7			4 or 5		
1940			c.12		
1948	c.20				
1952			3		
1953/4	30-56				
1954/5			c.3	1	1
1555/6		2	c.5		2
1956/7			c.4		
1957	c.50				
1958			c.7		
1958/9	c.65		c.8		
1964	72				
1965			14		
1965/6	75				
1968/9	75		12		
1968-72		28		4	32
1971/2			13		
1972/3		6	7		6
1973/4	21		7		
1975	23				
1978	19	1	8		1
1980	22	2			2
1981		1		1	2
1982		3			3
1983		1		1	2
1984		2		1	3
1985		2			2
1986	14		8		
1988	24				
1989	27		12		
1990				1	1
1991		1			1
1992	33	1		1	2
1993	34	1	15		1
Total					111

Sources: Bist, 1994, and Forest Department of West Bengal.

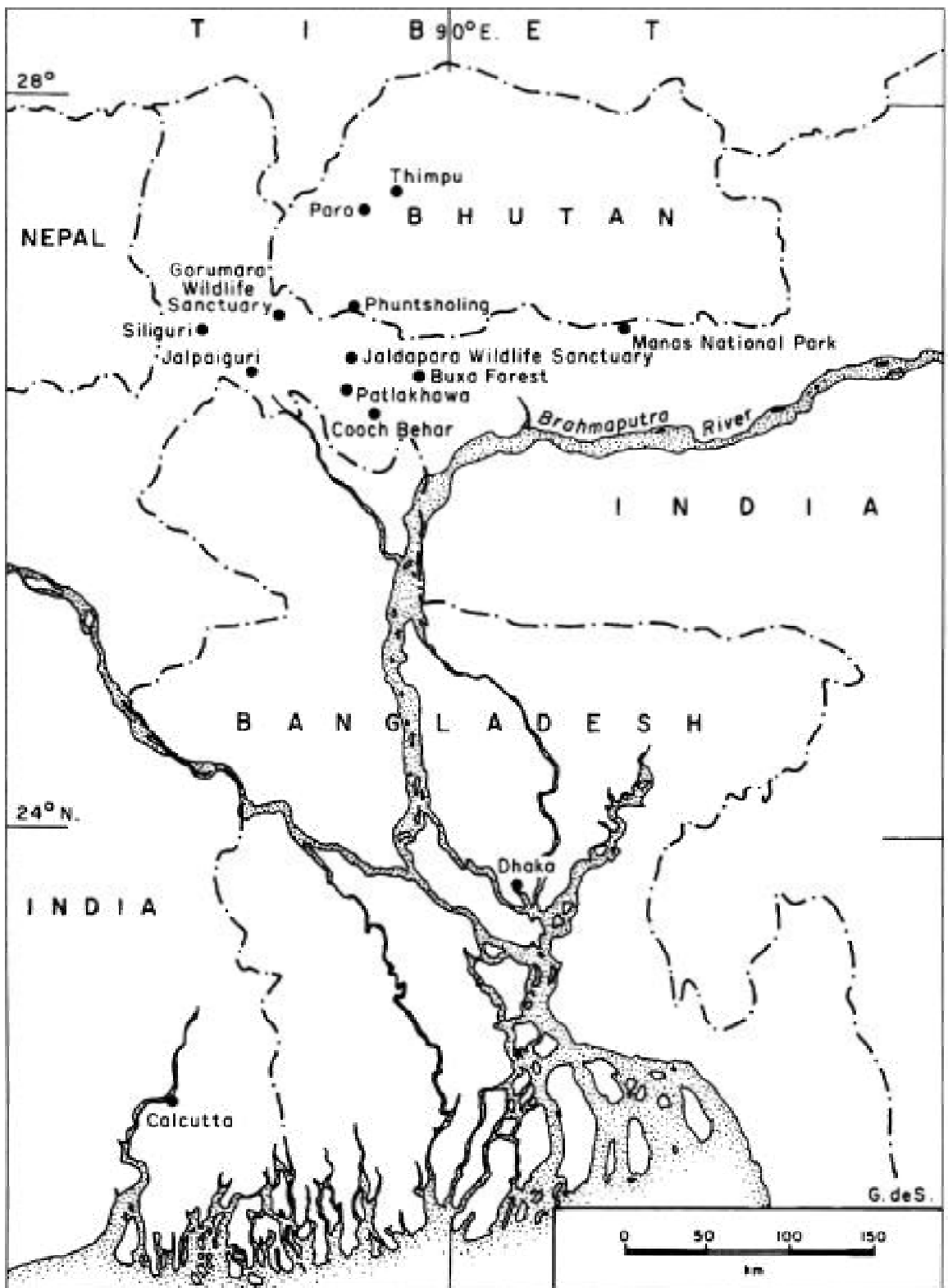

Map of West Bengal and surrounding region.

In the 1890s there were at least 240 rhinos in what is today the state of West Bengal. The majority were in the Jaldapara and Cooch Behar areas (Bist, 1994). By the late 1950s fewer than a hundred were left in West Bengal. According to Bist (1994), there were an estimated 65 in Jaldapara Wildlife Sanctuary, with a further 10 in the Patlakhawa region close by; around 10 more survived in the Buxa forest area north-east of Cooch Behar, and eight in the Gorumara Wildlife Sanctuary (see map). The main reason for the decline from the 1890s to the 1920s was legal hunting. One man, the Maharajah of Cooch Behar, killed more rhinos than anyone else: 207 between 1871 and 1907 (Nripendra, 1908). After 1932, with the exception of the Maharajah and his family, nobody was allowed to hunt rhinos. The continued decline in rhino numbers was due mainly to poaching for horn exported to eastern Asia. By 1970 the Buxa population had disappeared, as did rhinos from Patlakhawa two years later (Bist, 1994). By 1986, the number of rhinos in West Bengal had dropped to a mere 22, probably the lowest number ever.

Serious poaching occurred from 1968 to 1972 when 32 rhinos were known to have been killed, 28 of them in Jaldapara (Bist, 1994). During the 1970s, officials raided houses surrounding Jaldapara and Gorumara and some rhino horns were found, but there were very few convictions. The methods used by poaching gangs and trading syndicates were too sophisticated for the Forest Department staff. There were at least three groups involved in rhino poaching in Jaldapara during the 1970s. Their family names were “Karjee”, “Baraik” (both belonging to the Mech community) and “Tamang” (from Nepal), according to S.C. Dey (Additional Inspector General of Forests, Wildlife, Government of India) who was working in West Bengal at that time (pers. comm., 1995). After a poacher had killed a rhino, he would immediately escape from the sanctuary and tell another member of the gang to go and fetch the horn from the carcass. This made it more difficult for the authorities to apprehend all the gang members (B.K. Bardhana Roy, Conservator of Forests, Wildlife, West Bengal, pers. comm., 1980).

The last serious poaching in West Bengal occurred in 1972/3 when six rhinos were killed in Jaldapara. The aftermath of the fighting in East Pakistan (which in 1971 became Bangladesh) was a major cause of this, since the breakdown of law and order encouraged poachers and traders to enter neighbouring West Bengal.

In the late 1960s in the northern part of West Bengal, there was some demand for rhino horn for use in



Signs are seen around the tea plantations near Jaldapara Wildlife Sanctuary for the purpose of encouraging local concern for rhinos.

medicines, but this had declined sharply by the early 1970s (Dey, pers. comm., 1993). In the 1960s and 1970s most horn was smuggled by various trading syndicates to Calcutta. It was then exported illegally from Calcutta to eastern Asia (Bardhana Roy, pers. comm., 1980). Demand in West Bengal and elsewhere in India was insignificant compared with such places as Singapore and Hong Kong where also the price for the horn was far higher. Although officials knew that Calcutta was the main exit point for rhino horn during this period, almost no horns were intercepted nor traders convicted. In 1978, however, at Calcutta's Dum Dum airport one horn was seized which had been consigned to Japan, the address of the sender being a Calcutta cemetery. In addition, there was strong evidence that some horn from West Bengal was sent at that time to Phuntsholing in Bhutan, via traders living in and around Hasimara, near Jaldapara (Dey, pers. comm., 1995).

The number of rhinos poached in West Bengal fell to an average of only one a year from 1974 to 1989 (see Table). This was partly because more Forest Department staff were employed to protect the dwindling rhino population (Bardhana Roy, pers. comm., 1980) and because well-trained and armed homeguards and members of the national voluntary force were brought in and deployed in the Jaldapara Sanctuary to support the field forest staff in patrolling



Greater one-horned rhinos exist in three areas in India Assam with about 1,400, northern West Bengal with 47, and Dudhwa National Park in Uttar Pradesh with a re-introduced population of 12.



The Government of Bhutan strictly limits the number of foreign visitors to the country in order to maintain the people's traditional Buddhist culture. Few foreign conservationists are thus aware of Bhutan's trade in wildlife products.

(Dey, pers. comm., 1995). Employing local people ensured co-operation from the community, some of whom knew the secret plans of the poachers (J. T. Mathew, Divisional Forest Officer, Wild Life Division II, Jalpaiguri, pers. comm., 1993).

During the early 1990s, rhino poaching continued at low levels in both Jaldapara and Gorumara, with a total of five animals killed from 1990 to 1993 (see Table). Illicit hunters today are mostly West Bengalis, Bangladeshi refugees (often landless) and sometimes inhabitants of Assam. Both sanctuaries are surrounded by a huge and impoverished human population, which increases poaching pressure on the two small areas (in 1994 Jaldapara covered 216km² and Gorumara a mere 8.5km²). The poachers are organised into gangs by middlemen from West Bengal, Nepal and possibly Bhutan. The gangs usually kill rhinos in the early morning or late afternoon but sometimes hunt at night during a full moon. A typical gang consists of five

people: one shoots the rhino (using a muzzle-loader or modem rifle), the others remove the horn and hooves; on rare occasions (such as in 1991) the male reproductive organs are removed (V.K. Yadav, formerly Attached Officer, Wild Life Division II, Jalpaiguri, pers. comm., 1993). There are no records of meat being taken from a rhino. The poachers then bury the carcass to avoid detection.

Poachers are paid for each horn they obtain rather than by weight. In 1993 the price per kilo was from \$640 to \$896. Usually the killer, who is often the gang leader, will receive twice as much as the others. Sometimes the middleman who organises the gang pays up to half the money in advance and may supply the gun and ammunition.

From the 1960s even until the early 1980s, most rhino horn was exported to eastern Asia via Calcutta. This important smuggling route lessened progressively from the 1980s as officials increased their vigilance, with several forest check posts along the main road leading to the city (Mathew, pers. comm., 1995).

A second route for the movement of rhino horn from West Bengal then developed through the town of Siliguri (where several of the traders live) to Nepal. In 1985, the Indian authorities arrested a man with a rhino horn, who was on a bus in Siliguri ready to depart for Nepal. This has not become a major smuggling route, however, as Nepal is not an end market for rhino horn, and the authorities there are alert to the problem, having to control their own country's rhino poaching and rhino horn smuggling.

So through which route has most of West Bengal's rhino horn been leaving India in recent years? From confidential sources in West Bengal, Assam and Bhutan, it appears that traders in Bhutan from at least the mid-1980s to the present have been buying the majority of West Bengal's horns. Usually the horns are taken overland from Siliguri to Phuntsholing on the border with India in south-west Bhutan (see map). Phuntsholing is a trading town and, unlike other parts of the country, Indians can go there without a visa. Many Indian businessmen, especially Marwaris, as well as traders from Nepal and Bhutan, visit Phuntsholing in order to buy and sell various goods. Rhino horns from West Bengal are brought to Phuntsholing sometimes by people of the Bodo tribe (originally from Assam) living in West Bengal (where they are called "Mech"). In 1992 they sold the horns to Bhutanese for around \$8,600 a kilo. Bodos also bring to Phuntsholing horns from rhinos poached in Assam, especially from Manas National Park.



In the northern part of West Bengal elephants are responsible for considerable crop damage so electric wires are put up as a deterrent Rhinos, however, cause very little damage compared with elephants.

There are three main pieces of evidence verifying Phuntsholing's role in the rhino horn trade. First, there have been several seizures of Indian horns in and around this town. There has even been some trade in African rhino horn. In 1984, one African horn weighing 2.2 kilos was confiscated by Indian officials. Second, the state governments of India pay informers who have reported on this trade route. And third, a Bhutanese Princess educated at Cambridge University, Dekichoden Wangchuck, aunt of the present King (the King's father's half sister) was arrested at Taipei's Chiang Kai-shek airport in September 1993 with 22 Indian rhino horns, the biggest consignment of Asian horns ever intercepted in Taiwan.

The Princess's 22 horns ranged in weight from less than 100gm to over one kilo with a total weight of 14.9 kilos. Nearly all the horns would have originated from Assam, especially Manas, but a few could have come from West Bengal. In an interview carried out by Joe Loh of TRAFFIC Taipei on 20 September 1993, she claimed to have obtained these horns from Indian traders coming to Bhutan during the previous year. She explained that she owned a company (Dezany Beverages) near Phuntsholing and that businessmen periodically offered

her horns. She denied buying any horns directly from poachers. This Princess had bought the horns for \$6,666 a kilo on average. She said she knew there was a major demand for them in Hong Kong, so first she flew there with the horns, but she did not have “reliable” contacts among Hong Kong’s medicinal traders and after 15 days failed to find a buyer. She then went to Taipei where she was arrested after officials found the horns, using a routine x-ray machine.

Bhutanese smugglers usually transport rhino horn by road from Phuntsholing to the only airport in the country at Paro. The airport was opened in the early 1980s, but only the national airline, Druk Air, is allowed to use it, due to the hazards of landing and taking off in the high mountains. The airline at first used two small German-made aeroplanes (Dorniers) to fly to Calcutta, Dhaka and Kathmandu. In the mid-1980s one BAE 146 aircraft (with four jet engines,



Farmers living near Jaldapara sit on “machans ‘or elevated platforms, such as this one, scaring away wild animals at night from their fields.



In the dining room of the Maharajah of Cooch Behar's Palace, rhino heads decorated the walls until the Palace was abandoned by the family in the early 1970s.

carrying 70 people) was introduced to fly to Kathmandu, Dhaka, Calcutta, Delhi and Bangkok in order to replace the smaller Dorniers. In 1992, Druk Air obtained another BAE 146. From 1985 to the present, nearly all the horns from Bhutan have been transported by Druk Air, probably to Dhaka and Bangkok. Other trade routes from Bhutan are unlikely. It is very improbable that rhino horn sold in Bhutan would be sent back by road to neighbouring India or to Nepal as neither country is an end market and there would be more chance of the horns being detected. Rhino horns would not be moved northwards through Tibet, due to the lack of a modern transport system to Tibet, nor to China because the Chinese cannot afford to buy Asian rhino horns, which are ten times the price of African horns.

A few knowledgeable officials in the Indian state governments have known that influential Bhutanese have been exporting rhino horn at least since the mid 1980s. Some of these Bhutanese have diplomatic passports which notoriously assist them to move rhino horn from one country to another as their luggage is rarely inspected. (Bhutanese do not have diplomatic immunity in Taiwan, however, as their government does not recognise Taiwan as a country; this explains the Princess's 1993 arrest.) In 1994, one trader from Bhutan's capital, Thimpu, even had the audacity to use a business card stating that he was a trader in rhino horn.

With the continuing demand for rhino horn, the government of West Bengal in the last few years has improved its intelligence gathering and law enforcement efforts concerning rhino poaching, and the Forest Department has increased the budget for both Jaldapara and Gorumara. In 1993 Jaldapara employed 105 staff, and had 48 firearms, four vehicles and at least 12 domestic elephants. The total budget for the financial year 1993/94 (including capital costs and an eco-development scheme to help improve the standard of living for villagers surrounding the sanctuary) was \$847 per km², one of the highest budgets in Asia. In 1993 the Gorumara sanctuary employed two foresters, six forest guards and 15 casual daily labourers who also helped to protect the area. The staff possessed at least four guns and two domestic elephants. This tiny sanctuary spends even more money per km² than Jaldapara.

The recent improvement in intelligence gathering and the increase in money allocated to Jaldapara and Gorumara have been effective in curbing rhino poaching. The rhino population of Jaldapara has increased from 14 animals in 1986 to 34 in 1993, an annual increase of 13.5% which is one of the highest recorded in the world. Gorumara had eight rhinos in 1986 and 15 in 1993.

In order for the Jaldapara and Gorumara rhino populations to continue expanding, the West Bengal Forest Department will have to keep spending relatively large amounts of money to protect the sanctuaries and maintain its intelligence network for identifying poachers, traders and trade routes. Appropriate action must be taken against all those involved in this illicit trade, from the poor poacher to the top trader.

Postscript

By the end of 1995 the rhino population of Jaldapara had increased to 35 and Gorumara had 18. West Bengal's rhinos include two sub-adult males which were introduced in October 1995 from Assam to improve the gene pools of the two rhino populations. Gorumara was made a National Park in 1995 and was increased in area to 79.45km².

ACKNOWLEDGEMENTS

Thanks are due to WWF International and the Wildlife Conservation Society for funding this research in India in 1993, and to B.K. Bardhana Roy, S.S. Bist, S.C. Dey, A. Kumar, J.T. Mathew, V. Menon, M.K. Nandi, J. Williams and V.K. Yadav, for their valuable information. S.C. Dey and J.T. Mathew and Nigel Leader-Williams were very helpful in reading the original manuscript and for giving their important comments.

REFERENCES

- Bist, S.S. (1994) Population History of Great Indian Rhinoceros in North Bengal and Major Factors Influencing the Same. *Zoos' Print*. IX, No. 3-4,42-51.
- Nripendra Narayan Bhupa, Maharajah of Cooch Behar (1908) *Thirty-seven Years of Big Game Shooting in Cooch Behar the Duars, and Assam. a, Rough Diary*. Times Press, Bombay.

A PHOTOGRAPHIC METHOD FOR IDENTIFYING BLACK RHINOCEROS INDIVIDUALS

Max Morgan-Davies

PO Box 24944 Nairobi Kenya

INTRODUCTION

A fundamental requirement for the successful monitoring of a rhino population is the positive identification of each individual animal by way of its physiological and morphological characteristics. Such features include age and sex, front and rear horn shapes, body scars and blemishes, the location of cuts and notches on the ears, the extent and distribution of the fringe of hair on the ears, the skin creases under the front horn and between the nostrils, and finally, the size and individual pad lines on the base of the feet. Occasionally, even behavioural characteristics are a useful aid to the identification of individual animals.

The larger the population under study, the greater the problem becomes in recognising the individual physical characteristics of each animal. Normally, the most obvious individual identification characteristic of a rhino is its two horns. However, two or more animals can have horns so similar in size and shape that positive identification becomes very difficult, particularly when observations are being conducted either in heavy bush or at long range, or when an assessment has to be made in a hurry. The proficient use of a suitable camera with a telephoto lens alleviates many of these problems.

Photography, to a great extent, clarifies the exact shape and size of the horns of each individual animal, thus providing a useful method of identifying one animal from another.

During a recent study of the 40 black rhinos resident within the Masai Mara National Reserve in Kenya, a method was devised whereby not only the shape and size of horns were ascertained but also their actual measurements were determined with reasonable accuracy.

METHOD

On every possible occasion during surveillance operations, a profile photograph (side not important) of the head of each animal encountered was taken.

Each profile portrait was taken in silhouette against the background of the sky or at least with a blurred background, and was taken as close as possible to the animal, depending on the lens in use, so that the rhino's head filled the picture.

Before printing each negative, a suitable size template was prepared from a photograph of an adult black rhino (sex immaterial) in distinct profile. It is important that either or both the left or right nostril and eye are clearly defined on the template, as illustrated in Figure 1.

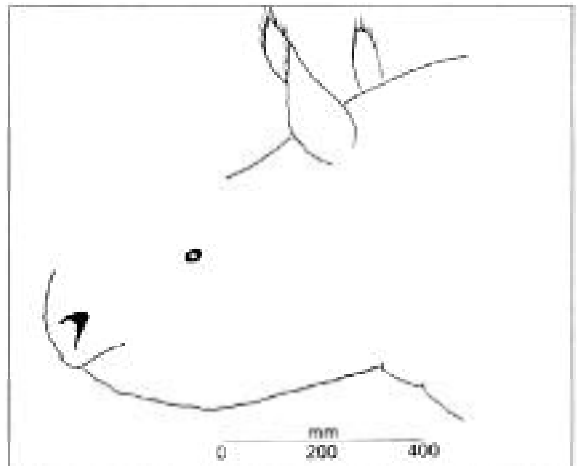

Figure 1. Template of head profile, showing position of nostril and eye, onto which horn details are added to give precise identification picture.

The negative was then inserted into the enlarger and the template placed below the enlarger lens. The enlarger was then adjusted either upwards or downwards until the head of the rhino in the negative was superimposed, with its nostril, eye and head profile as close as possible to the head details on the template. The template was removed and its place taken by photographic paper. The exposure was made and the paper developed, as shown in Figure 2.



Figure 2. Negative image adjusted in the enlarger to fit the template as close as possible.

Based on the known measurement of ca.260mm between the nostril and the eye of an adult black rhino (Rob Brett, pers.comm.), it was then possible, with reasonable accuracy, to determine the length and shape of each of the horns of the photographed animal. In addition, the forward and/or backward tilt of the horns on the animal's head were ascertained. The result was a much more accurate portrayal of the shape and size of the animal's horns than that obtained from a field sketch, as demonstrated in Figure 3.

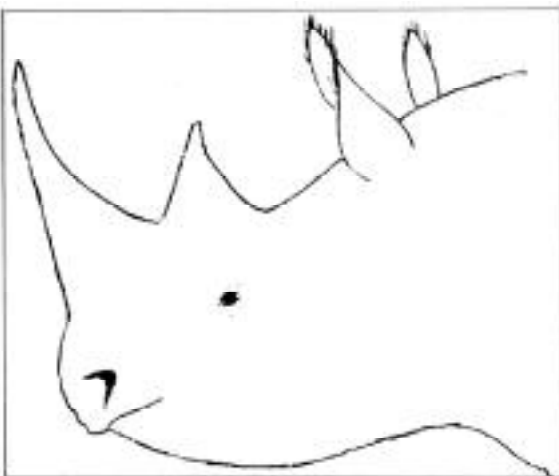

Figure 3. Negative image superimposed on template to give precise identification picture of "Wanjiru" in October 1993.

As shown in Figure 4, the final results are then transcribed, with the aid of tracing paper, to the individual identification card of the animal concerned.

REGISTRATION NUMBER: 1507 NAME: WANJIRU SEX: ♀ DATE OF BIRTH: ca. 1980 HOME RANGE: AREA C AREA OF HOME RANGE: ca. 31Km ² DATE: October 1993	
Corrugations on left side of rib cage very noticeable 	Corrugations on right side of rib cage very noticeable
Front horn ca.450 mm. Back horn ca.180mm. and slightly tilted backwards.	
Small notch at lower outside of left ear. Hair line thick. 	
HORN PROFILE 	

Figure 4. An example of an identification card

CONCLUSION

Photographic information of this nature, together with other known individual physiological and morphological characteristics, renders individual rhino identification and monitoring records more reliable. It helps to provide a dependable and ongoing record of subtle horn changes that take place, and which often can only be established by photography. It also helps to identify those animals with horn characteristics which are superficially similar, to the

print of possible confusion. As horn characteristics slowly change over time it is recommended that each animal in a population be suitably photographed at least once every two years, and more frequently if possible.

ACKNOWLEDGEMENTS

I would like to thank Mrs. Jorie Butler Kent, Chairman of Friends of Conservation, for the opportunity to undertake this study.

Photo credit: Max Morgan-Davies



An adult female black rhinoceros Dicerus bicornis michaeli in the Masai Mara National Reserve, Kenya.

STATUS OF THE BLACK RHINOCEROS IN THE MASAI MARA NATIONAL RESERVE, KENYA

Max Morgan-Davies

PO Box 24944 Nairobi Kenya

INTRODUCTION

It is generally acknowledged that the population of black rhino *Diceros bicornis michaeli* in what is now the Masai Mara National Reserve (the Reserve) during the mid-900s probably numbered between 150-200 animals (Brett, 1995). However, as a result of poaching, the thinning of the *Croton dichogamus* thickets (that are such a characteristic feature of the Mara and northern Serengeti), and an appreciable increase in elephant numbers (Dublin, 1991), this figure has been greatly reduced. By 1972 there were known to be only 108 rhinos remaining in the Reserve (Mukinya, 1973). In the following decade poaching continued and by 1985 the population of rhinos had been reduced by over 80% to fewer than 13 animals (Brett, 1995). The status of the black rhino had reached crisis point in the Reserve.

In early 1980, in an attempt to halt the continued poaching and almost certain extinction of the species within the Reserve, a special rhino surveillance team was established and jointly administered by the Narok County Council (NCC), custodian of the Reserve, Friends of Conservation (FOC), then Friends of the Masai Mara, World Wide Fund for Nature, and the then Wildlife Conservation and Management Department of Kenya. Since 1983 the surveillance team has been administered solely by FOC in collaboration with NCC and their rangers.

Although the rhinos of the Reserve have been under surveillance since 1983, it was only during the period of this study (1992 to 1995) that the population was once again monitored with a view to acquiring more up-to-date information on the population of this large, free-ranging black rhino population in Kenya. The only previous studies of these animals in the Reserve were made in 1971 and 1972 by Mukinya (1973, 1977).

Within a span of 12 years rhino numbers have trebled to a healthy population of 40 animals. The increase has been due to improved surveillance and

monitoring, the cessation of rhino poaching within the Reserve, the birth of 25 calves and the identification of four, hitherto unrecorded animals during the period of this study.

This paper outlines the present status of the black rhino in the Reserve and makes certain comparisons with the findings of Mukinya (1973). It also offers recommendations for the future long-term security and management of these animals.

STUDY AREA

The Reserve is centred on 1 30'S and 35 0 'E in the Narok District of Kenya, approximately 200km southwest of Nairobi. It covers an area of 1,510km² (Cumming *et al.*, 1990). Altitude varies from 1,450m ASL along the lower reaches of the Mara River where it crosses the Kenya/Tanzania international boundary, to 1,950m on top of the Siria Escarpment and Ngama Hills to the west and east respectively.

The Reserve forms the northern portion of the Serengeti/Mara ecosystem (Dublin, 1991). It is bounded on the north-east by the Loita Plains, on the east by the Laleta Hills, on the west by the Siria Escarpment, and on the south by the northern Serengeti National Park.

There is an annual mean gradient in rainfall across the Reserve from ca. 900mm in the east around the Ngama Hills to ca. 1,500mm in the west along the Siria Escarpment (Masai Mara Ecological Monitoring records).

The poorly drained "black cotton" soil areas supports the vast undulating areas of *Themeda triandra* grasslands that are the major vegetation community of the Reserve. This is the dry season habitat for the annual migration of wildebeests, zebras and Thomson's gazelles from the adjoining Serengeti National Park. The grasslands are intersected by the Mara, Talek and Sand Rivers and their numerous tributaries. The riverine forests and thickets provide shelter and security for

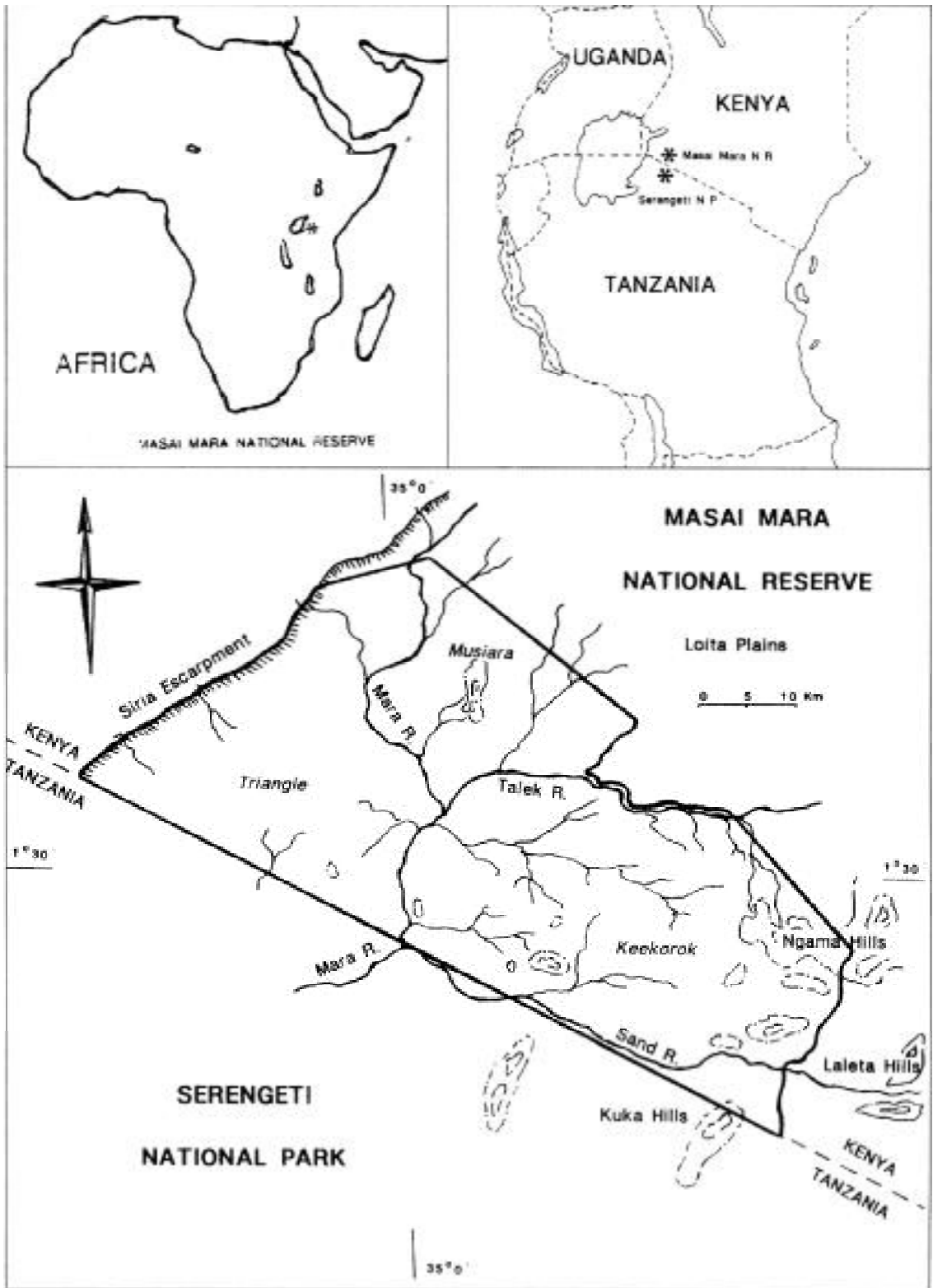

Figure 1. Map of the Masai Mara National Reserve, Kenya, in relation to the Serengeti National Park, Tanzania.

rhinos. But it is the higher ground and hills with their shallow, porous, sandy soils, their greater cover of *Croton* and *Euclea* thickets, with the possibly greater abundance of herbs, legumes, shrubs and other favoured food plants, that constitute the preferred habitat for the majority of rhinos.

METHODS

At every opportunity during the study period all rhinos were photographed at as close a range as possible either from a vehicle or on foot. Individual identifications were further enhanced by using physiological characteristics such as gender and age class (Hitchins, 1970), and various morphological characteristics such as horn shape and size (Morgan-Davis, 1996), permanent body scars, the location of cuts and notches on the ears, and the distribution and extent of the fringe of hair on the ears.

Rhino locations were initially established by the use of three point azimuth bearings and later in the study with the use of a Global Positioning System (Trimble Navigation) using the UTM grid system. These bearings were then entered onto a 1:50,000 topographical map from which home ranges and distribution areas, as defined by Mukinya (1973), were determined.

Individual home range sizes were assessed by computing the area of a polygon by connecting the recorded peripheral points of each home range. Distribution areas were determined from groups of rhinos whose home ranges overlapped to a considerable extent. The measured home ranges, distribution areas, and population statistics were then compared with the findings of Mukinya (1973).

DISTRIBUTION AND DENSITY

In the mid-1900s, the Masai Mara had a justified reputation as being a haven for wildlife. Rhinos were reported to have occurred in relatively large numbers in suitable habitats throughout the Reserve. The majority were located in the Triangle area, some in the Keekorok area and a few in the Musiara area - in total, an estimated 150-200 animals (Jack Barrah, pers.comm.).

However, in the 1960s, as a result of extensive poaching for rhino, combined with the destruction of the habitat by constant, uncontrolled, annual (and even biannual) bush fires and an exceptionally heavy influx of elephants seeking asylum in the Reserve (Dublin,

1991), rhino numbers declined appreciably. By 1972 only 49% of the area was occupied by 108 rhinos in 13 separate distribution areas (Mukinya, 1973), as shown in Figure 2A as areas A to M.

Persistent and extensive poaching during the following ten years resulted in the further removal of many of the remaining rhinos. This was most noticeable in the Triangle area west of the Mara River, the area between Sand River and the Kuka Hills where rhinos have been eliminated, and in the Musiara area where only a single animal remains. Only 30% of the Reserve is now occupied by 40 rhinos in five distribution areas (A-E), all of which are located east of the Mara River, as illustrated in Figure 2B.

The present study indicates that the configuration of rhino home ranges and distribution areas have altered considerably over the past 20 years.

Home ranges

Home range sizes for seven of the II adult males and five of the 13 adult females vary from seven to 126km², with a mean of 46km². Female home ranges are slightly larger than males. Females range from 12 to 126km², with a mean of 51km², while males range from seven to 83km² with a mean of 42km². No account has been taken of eight adult rhinos whose home ranges extend into the northern Serengeti though the extent of their ranges within the Reserve are known.

In 1971/72 when Mukinya (1973) did his studies, the Reserve rhino densities were higher and overall home ranges were smaller, varying from 5.6km² to 22.7km² with a mean of 13.1km².

The marked increase in the size of home ranges can be possibly attributed to each or a combination of the following:

- Reduced competition for suitable habitat
- Reduction in food resources due to annual, uncontrolled fires
- Deterioration of the environment caused by excessive, off-road driving by thousands of tourist vehicles each year
- Increased searching for mates by rhinos due to their lower densities

Distribution areas

The Reserve presently has five distinct rhino distribution areas (Table 1) comprised of closely overlapping individual home ranges of more than one rhino except for Musiara (E), with only one remaining animal. Currently 22(55%) of the Reserve's 40 rhinos are resident in area A, which has always had a relatively large number of these animals. Mukinya (1973) also records this as being a heavily populated area with 31 (29%) of the 108 rhinos then resident in the Reserve. However, area A is the largest. In terms of density, area D supports the highest number of rhinos per km², as seen in Table 1.

Table 1. Individual distribution areas, numbers of rhinos and their relative densities in June 1995

Area	Number of rhinos	% of total population	Distribution area in km ²	Number of rhino per km ²
A	22	55.0	181	0.12
B	7	17.5	118	0.06
C	4	10.0	58	0.07
D	6	15.0	16	0.38
E	1	2.5	86	0.01
Total	40	100.0	459	0.09
Excluding area of overlap	40	100.0	399	0.10

Overlap of distribution areas

Although four of the five distribution areas presently overlap (Figure 2B), Mukinya (1973) recorded that overlaps only occurred with home ranges and not with distribution areas, and that the latter were clearly separated from each other (Figure 2A). At present there are three distinct distribution area overlaps totaling 60km² or 16% of the total area occupied by rhinos east of the Mara River (12km² in areas A-B, 38km² in areas A-C, and 10km² in areas B-D). It is possible that these overlaps allow the exchange of genes between members of adjacent distribution areas. Rhinos from geographically separate distribution areas were seen consorting in these overlaps on at least ten occasions between 1992 to 1995 but no mating was observed. In each instance, the rhinos

involved had returned to their respective home ranges within two to four days.

Density

Mukinya (1973) records that the total area of the Reserve occupied by rhinos in 1972 was 749km², thereby giving a density of 0.14 rhino per km². At present the total area occupied by rhinos is only 399km², with a density of 0.10 rhino per km². However, taking into account the 60km² overlap of distribution areas (Figure 2B), the total area occupied by rhinos is 459km², with a corresponding density of 0.09 rhino per km².

Movement of rhinos into and out of the Reserve

Not only is the Reserve an integral part of the Mara/Serengeti ecosystem on account of the annual migration of about two million ungulates, but also due to the movement, throughout the year, of at least 15 rhinos (the majority being females with their calves) between the Mara and northern Serengeti. These movements are not without their dangers. Although the rhinos move from one protected area to another, they run the considerable risk of being poached by cattle raiders which infiltrate the Park and Reserve along the Serengeti/Mara international boundary to steal Maasai livestock on the Reserve's western and eastern boundaries. There could also be the occasional movement of one or more rhinos between the Reserve and the Laleta Hills, four to five kilometres east of the Reserve. Two or three times each year, reports are received of rhinos being seen within the Maasai group ranches, up to eight kilometres north of the Reserve. These could be sub-adult animals from the Reserve trying to establish home ranges, or adults in search of mates.

POPULATION STRUCTURE AND RECRUITMENT

At the present time, the Reserve holds a modest and healthy population of rhinos, as shown in Figure 3, despite their near elimination in the Masai Mara between the 1960s and 1980s.

The adult male: female ratio of 1:1.2 compares favourably with Mukinya's (1973) figure of 1:0.9, though the present cow:calf ratio of 1:0.6 is slightly less than Mukinya's (1973) figure of 1:0.8. However, indications are that between three to four calves might be born during 1996 which would improve this ratio.

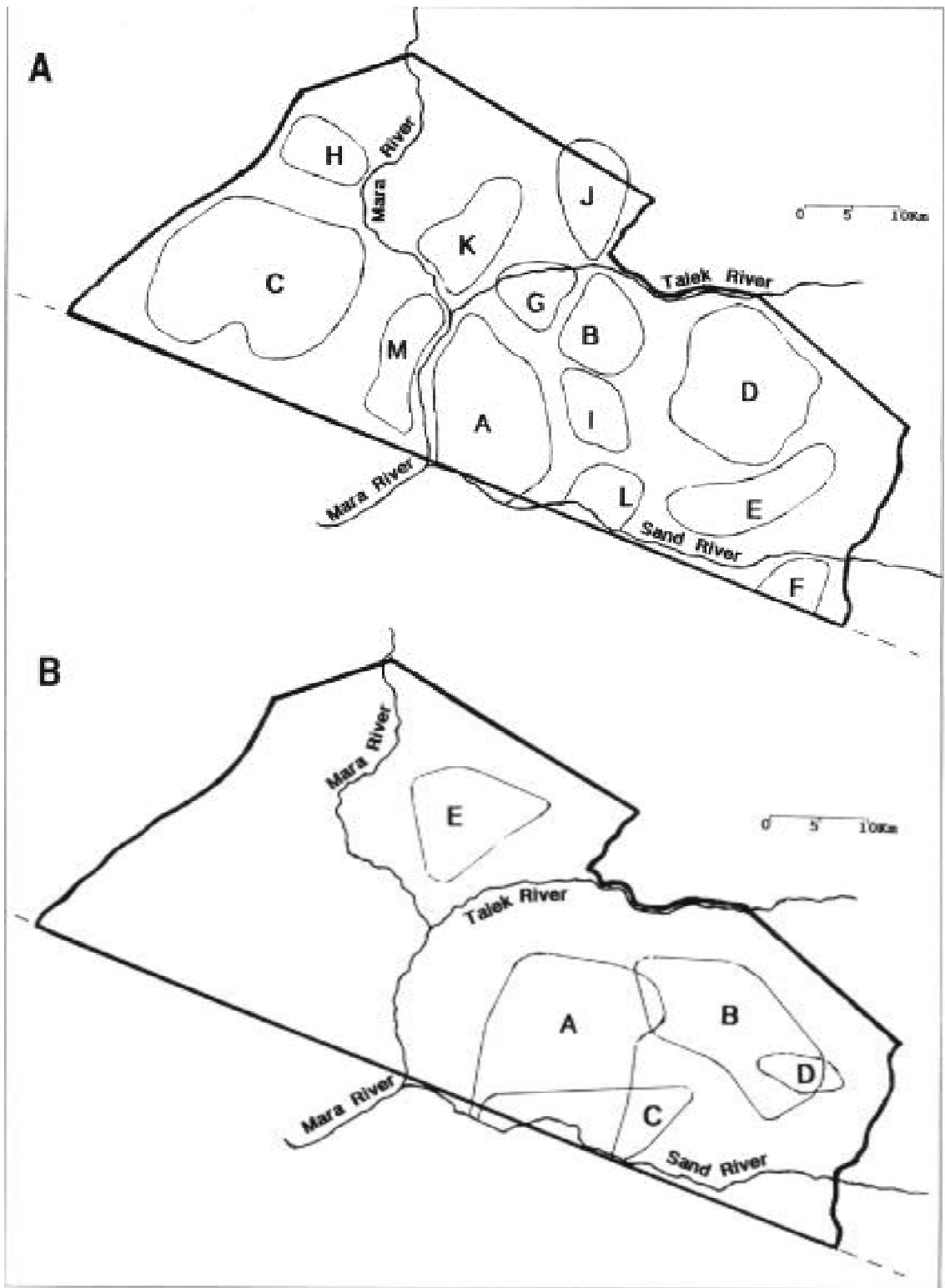

Figure 2. Comparative distribution areas of black rhinos in the Masai Mara National Reserve in A) 1972 (Mukinya, 1973) and B) 1995

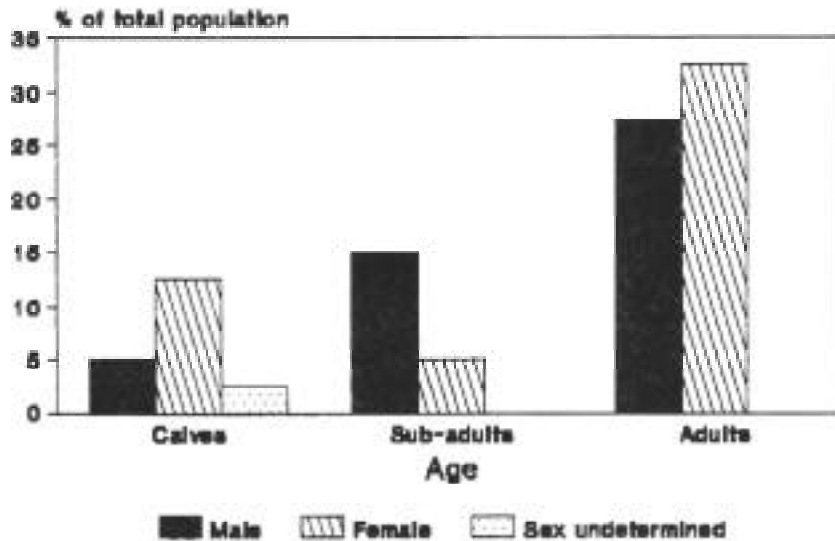

Figure 3. Population structure, by age and sex, of the black rhino population in the Masai Mara National Reserve in 1995

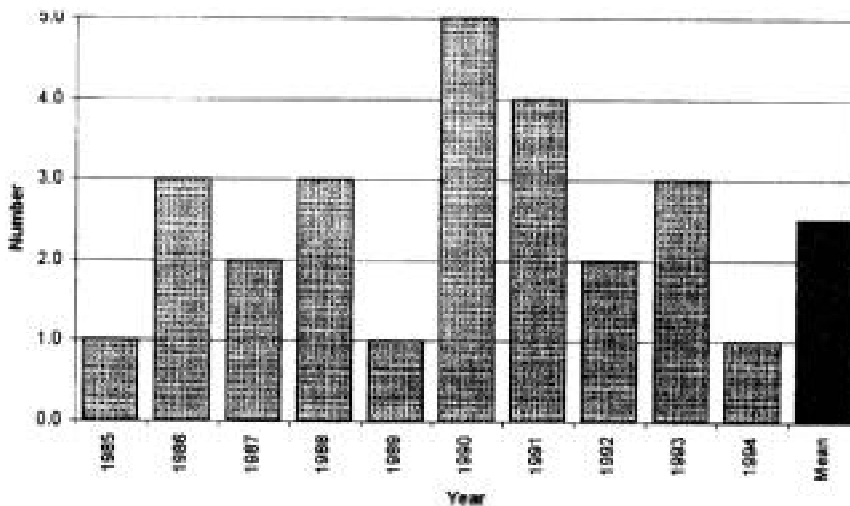

Figure 4. The number of black rhino calves born in the Masai Mara National Reserve from 1985 to 1994

Figure 4 illustrates the number of calves born between 1985 - 1994 and shows that the mean number of calves born per annum over the past ten years is 2.4. Assuming that the population remains stable and that an average of 2.4 calves continue to be born each year it should be possible for the population to reach 50 rhinos by the year 2000.

Calving intervals

The calving interval, to the nearest month, is known in 11 cases and varies from 16-34 months, with a mean of 25.4 months.

The only record of the age at maturity of a black rhino in the Reserve is that of Chebrech, who is recorded to have been born in May 1984 and who produced her first calf in December 1991. Based on a mean gestation period of 454 days (Hitchins & Anderson, 1983), Chebrech probably conceived in September 1989, at 64 months (5.4 years) of age.

RECOMMENDATIONS

Despite the accomplishments of FOC and the NCC over the past decade, there is no room for complacency. What has been gained in ten years could be lost overnight. The following recommendations are made in the long-term interests of rhino management within the Reserve.

Fire management

Uncontrolled, annual (and sometimes biannual), hot fires, are having a notable and deleterious effect on the remaining thicket and woodland habitat of the rhino, specifically with regard to food resources. Fire is not a new phenomenon for the Reserve for it has played an important role in the vegetation dynamics of the area over a long period (Dublin, 1991). If permitted to continue, uncontrolled fire will lead to the loss of even more valuable rhino habitat. The management authorities must decide now if the Reserve should remain a predominantly grassland habitat, which is what it is at present (and which is largely unsuitable for black rhino), or if fires should be managed and controlled, thereby maintaining and improving a mixed woodland and grassland habitat. Improved habitat management would cater both for the annual migration of grazers from the Serengeti and for the maintenance of the largest, free-ranging population of the black rhino in Kenya. The Reserve

has had an approved fire management plan since 1993 but its implementation is now long overdue. This, together with a study of the impact of fire on rhino habitat, feeding patterns and browse availability, is a priority.

Movement of rhinos between Masai Mara and the Serengeti

Between 1992 and 1995 the standard of rhino surveillance and monitoring improved appreciably. An important outcome of this has been better knowledge of the individual rhinos and greater awareness of the extent of their movements back and forth between the Reserve and northern Serengeti. Rhinos require exceptionally close surveillance, monitoring and security. Although there is an anti stock-theft unit in the vicinity to monitor and combat cattle rustling and to help the security of visitors in the area, its duties do not officially include surveillance or security of the local rhino population. A dedicated ranger post should be placed at a strategic location along the Sand River, from where a minimum of six, suitably equipped rhino surveillance rangers can operate. In addition, some form of regular and joint Mara/Serengeti rhino surveillance and monitoring patrols should be undertaken along the Kenya/Tanzania international boundary.

Illegal encroachment of livestock

Black rhinos are normally very shy of cattle and have had to abandon about 50km² of two prime habitats in the Reserve, one immediately south of the Talek River, the other in the northern Ngama Hills. Continuous, illegal incursions into these two areas by hundreds of domestic livestock, which originate from neighbouring group ranches on the Reserve's northern boundary, are denying the rhinos two important habitat localities in the Keekorok area. The Reserve's new by-laws cater for the prosecution of illegal grazing and they should now be strongly enforced.

Ranger training

Since the inception of a ranger force specifically for rhino surveillance and monitoring, inadequate attention has been given to the practical and theoretical training of these men and their officers. A suitable in-service training programme similar to that of the Natal Parks Board (Sandwith, 1990), incorporating aspects of rhino biology and the status of the rhino as a highly valuable, endangered species is urgently required. After successfully completing such a programme, the rangers should not be withdrawn or replaced after only

Photo credit: Max Morgan-Davies



Many of the Croton dichogamus thickets have already been destroyed by fire. Others are being reduced in area as wild fires encroach on their peripheries, thereby denying rhino the benefit of important areas of cover and security.

a few months of service as is frequently the case now. The long-term presence of motivated and well-disciplined personnel who have an extensive knowledge of the individual rhinos under their charge and a high degree of esprit de corps, is an essential component of an efficient rhino surveillance, monitoring and security programme.

ACKNOWLEDGEMENTS

I would like to thank Mrs Jorie Butler Kent, Chairman of Friends of Conservation, for the opportunity to undertake this study. I am also grateful to the Chairman and Clerk of the Narok Country Council Mr. Shadrach Rotiken and Mr. Joseph Kayioni respectively, for their kind support. My thanks also to the Senior Wardens of the Masai Mara National Reserve, Mr. James Sindiyo and Mr. Michael Koikai, and to Sgt. Phillip Bett and his team of rangers, for their co-operation in the field. I would also like to thank Richard Emslie, Keryn Adcock and Charles Fraser for their constructive criticism of the initial draft of this manuscript, and also an anonymous reviewer for comments.

REFERENCES

Brett, R.A. (1995) Conservation strategy and management plan for the black rhinoceros (*Diceros bicornis*) in Kenya. Kenya Wildlife Service. Unpublished Report.

Cumming, D.H.M., Du Toit, R.F., Stuart, S.N. (1990) *African Elephants and Rhinos - Status Survey and Conservation Action Plan*. IUCN/SSC African Elephant and Rhino Specialist Group. IUCN, Gland, Switzerland.

Dublin, H.T., (1991) Dynamics of the Serengeti-Mara woodlands - an historical perspective. *Forest and Conservation History*. 35,169-178.

Goddard, J. (1967) Home range, behaviour, and recruitment rates of two black rhinoceros populations. *E.Afr. Wildl.J.* 5,133-150.

Hitchins, P.M. (1970) Field criteria for ageing immature black rhinoceros (*Diceros bicornis* L.). *Lammergeyer*. 12, 48-55.

Hitchins, P.M. & Anderson, J.L. (1983) Reproduction, population characteristics and management of black rhinoceros *Diceros bicornis minor* in the Hluhluwe/Corridor/Umfolozi Game Reserve Complex. *S. Afr. J. Wildl. Res.* 13,78-85.

Lamprey, H.F. (1979) Structure and functioning of the semi-arid grazing land ecosystem of the Serengeti region (Tanzania). In: *Tropical Grazing Land Ecosystems, Natural Resources Research XVI*. UNESCO.

Morgan-Davis, A.M. A photographic method for identifying black rhinoceros individuals. *Pachyderm* 21, 35-37.

Mukinya, J.G. (1973) Density, distribution, population structure and social organization of the black rhinoceros in Masai Mara Game Reserve. *E. Afr. Wildl.J.* 11,385-400.

Mukinya, J.G. (1977) Feeding and drinking habits of the black rhinoceros in Masai Mara Game Reserve. *E.Afr. Wildl. J.* 15,125-138.

Sandwith, T.S. (1990) A training programme for Game Scouts involved in the monitoring of black rhinoceros populations - Instructors Handbook. Natal Parks Board/Wildlife Society of Southern Africa.

OBSERVATIONS ON TWO INTRODUCED BLACK RHINOS IN LIWONDE NATIONAL PARK, MALAWI

Roy Bhima¹ and C.O. Dudley²

¹Liwonde National Park, PO Box 41, Liwonde, Malawi

²Museums of Maiawi, PO Box 30060, Chichiri, Blantyre ³, Malawi

INTRODUCTION

Two black rhinos (*Diceros bicornis minor*) from Kruger National Park, South Africa, were introduced to Liwonde National Park in Malawi on 27 October 1993. This marked the re-introduction of the species to Malawi where it had been officially declared extinct in 1990.

The last natural rhino populations in Malawi occurred in Kasungu National Park and Mwabvi Wildlife Reserve, as shown on the map in Figure 1. The most recent signs of these populations were recorded in 1985 and 1989 respectively. Ansell & Dowsett (1988) stated that in the past, rhinos were found virtually

throughout Malawi. For the area which is now Liwonde National Park, Dudley & Stead (1977) reported that the most pertinent record of rhinos was that of Murray (1922) which said that "rhinoceros would occasionally be tracked to the Masanje River".

The introduced rhinos are a male and a female, each about five or six years old at the time of translocation. When they were captured in Kruger, they were kept in bomas before being brought to Liwonde, where they were again kept in bomas for one-and-a-half months. They were released into a 1,500ha sanctuary with an electrified game fence. They will remain in the sanctuary until their security can be assured in the wider area of the Park.

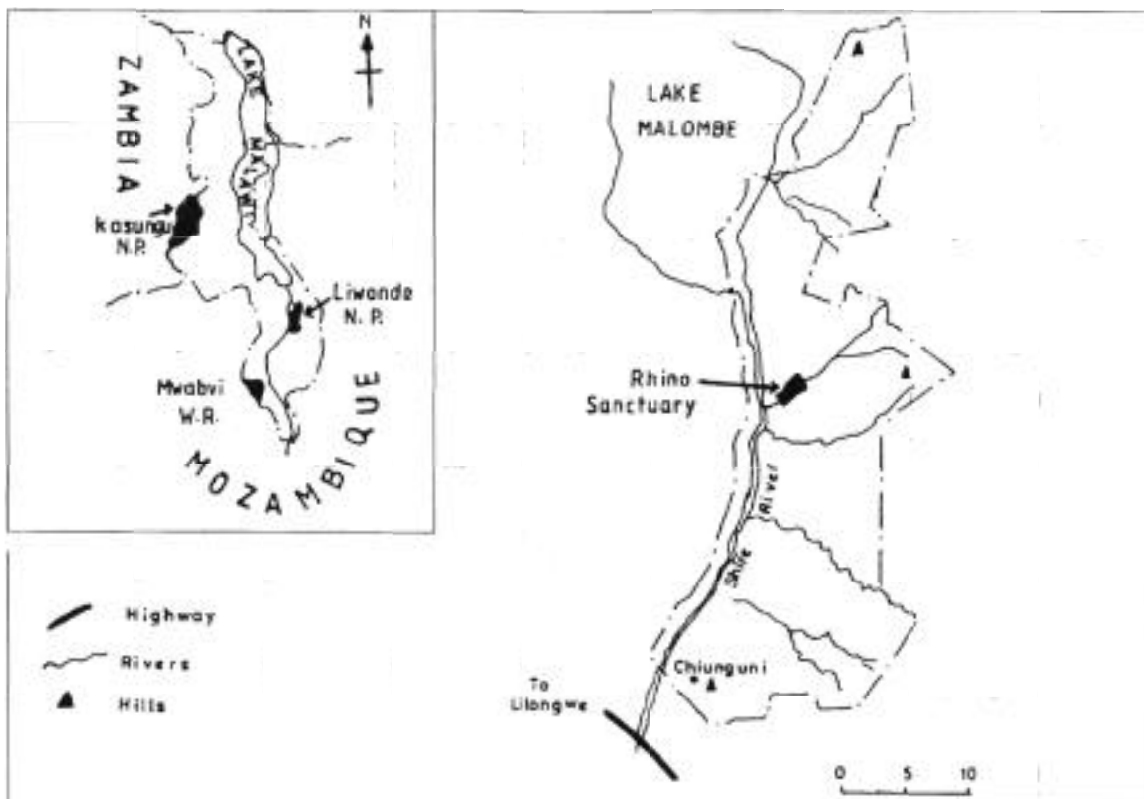

Figure 1. A map of Liwonde National Park, showing the major features and location of the rhino sanctuary. The inset shows a map of Malawi with the locations of Liwonde National Park, Kasungu National Park and Mwabvi Wildlife Reserve.

A programme to monitor vegetation in the sanctuary, along with the condition, movements and feeding behaviour of the rhinos, was initiated by the Wildlife Research Unit, in order to build up a base of biological information for effective management of the rhinos. This paper summarises the information collected on vegetation mapping of the sanctuary, observations of the rhinos in the bomas, their habitat preferences and movements in the sanctuary and some aspects of their feeding behaviour for the period November 1993 to April 1995.

THE STUDY AREA

Liwonde National Park (548km²) is located in the Upper Shire Valley, which is part of the Great East African Rift Valley in southern Malawi. The terrain of the Park is generally flat except for three isolated groups of hills. The Shire River is a prominent feature along the western boundary. The full width of the river, with its riparian habitat on both sides, forms part of the Park for a stretch of over 40km, as seen in Figure 1.

The main vegetation type in the Park is *Colophospermum mopane* woodland, which occupies about 70% of the total area of the Park. Other vegetation types are mixed woodland on the hills, floodplain, grassland and riverine forests/thickets, drought deciduous forest thickets and mixed woodlands on the hills, all of which occupy minor areas. For a detailed account of the flora and plant communities, the reader is referred to Dudley (1994).

The Park has a variety of mammals, of which the elephant and the hippopotamus are the keystone species. Other common species include the water-buck, sable antelope, impala, kudu and warthog.

The rhino sanctuary is located in an area predominated by *mopane* woodland, with a variety of other species such as *Dalbergia melanoxylon*, *Albizia anthelmentica* and *A. harveyi*. The Ntanga River cuts through the middle of the sanctuary with a border of riverine forest/ thicket, characterised by tall trees such as *Terminalia zambesiaca*, *Cordyla africana*, *Khaya nyasica* and *Diospyros mespiliformis*, with an understorey of *Friesodeilsia obovata*, *Markhamia* and *Diospyros* spp. The savanna of the river's floodplain supports a variety of tall grasses (1.5 - 2.5m) which include *Digitaria milanjiana*, *Hyparrhenia filipendula*, *Panicum maximum*, *Setaria sphacelata* and *Sorghastrum bipennatum* as well as scattered, large trees (15 - 25m) such as *Acacia nigrescens*, *Sclerocarya birrea* and *Xeroderris stuhlmannii*.

The climate is characterised by a dry season from April to October and a rainy season from November to March. According to records from the Park's weather station at Chiunguni, annual rainfall ranges from 700 to 1,400mm. Mean minimum temperatures range from 12°C in July to 28°C in November, with mean maximum temperatures of 20°C to 40°C for the same months. The first year the rhinos were in the Park (1994) was very dry, with a total recorded rainfall of only 639mm (unpublished meteorological data). All natural water pools had dried up by mid-July, 1994. However, an artificial water hole was maintained near the boma throughout the year.

Liwonde National Park was selected for the reintroduction of rhinos for security considerations. All its boundaries lie within Malawi (unlike Kasungu National Park and Mwabvi Wildlife Reserve) and it is therefore easier to police than Kasungu and Mwabvi. Access to the Park is relatively easy as the main road between Zomba and Lilongwe is only six kilometres from the Park's main entrance.

METHODS

Vegetation mapping

After identifying the sanctuary site, the area was fenced off and bomas were constructed in readiness for the rhinos. The sanctuary site was located from aerial photographs taken in May 1981 at a scale of 1:25,000. Units of vegetation which appeared to be homogenous from the photographs were marked and mapped and their area was estimated. Each unit was then checked on the ground in terms of its general structure and flora.

Rhino behaviour in the bomas

After their capture in Kruger, the rhinos were kept in bomas to minimise stress and to ensure that they were well adapted before translocation to Liwonde. On arrival in Liwonde, they were again kept in bomas where they were observed. In both places, observations were made at 07.00 hours, on body condition, health and behaviour. The results from Kruger and Liwonde were compared using the chi-squared test for significance.

While in the bomas, the rhinos were offered branches of different plants as food. The species which were eaten were recorded.

Preliminary observations of rhino movements, habitat preferences and food selection in the sanctuary

The rhinos were tracked to map out their movements in the sanctuary, to determine their preferred areas, to observe their general body condition and to record what they were eating. Their movements were marked on a vegetation map. Seasonal patterns of movement for the first year were determined by analysing data for three-month periods (January-March, April-June, July-September and October-December). The general patterns of movement for each of these three periods were then summarised and re-mapped.

The formula for preference index (PI), to determine habitat preferences, was adapted from Pienaar *et al.* (1992), for this data set. The calculations in the formula are based on the proportional occurrence of each vegetation/habitat type. A value of zero (0) indicates that a habitat type is used in the same ratio as expected from its proportional occurrence. A positive value (maximum + 1.0) indicates habitat use which is greater than expected from its proportional occurrence, while a negative value (minimum - 1.0) indicates habitat use less than expected from its proportional occurrence.

Plant species eaten by the rhinos

The plant species eaten by the rhinos were recorded by observing the rhinos feeding while they were in the bomas, and by checking for damage of the plants along the rhino tracks after their release into the sanctuary. Rhino browse characteristics are quite distinctive and are unlikely to be confused with other browser sigus in the sanctuary, such as those of the kudu or impala.

Feeding observations were also divided into threemonthly records in order to detect plant species eaten throughout the year as well as seasonal differences.

RESULTS

Sanctuary vegetation

Three major vegetation communities were identified in the sanctuary. Two of these were further subdivided, as shown on the map in Figure 2. The most important in terms of plant cover is the *mopane* woodland complex which is sub-divided into four variants: *mopane* woodland with or without coppice (45%); *mopane* woodland with *Croton* thicket (0.1%);

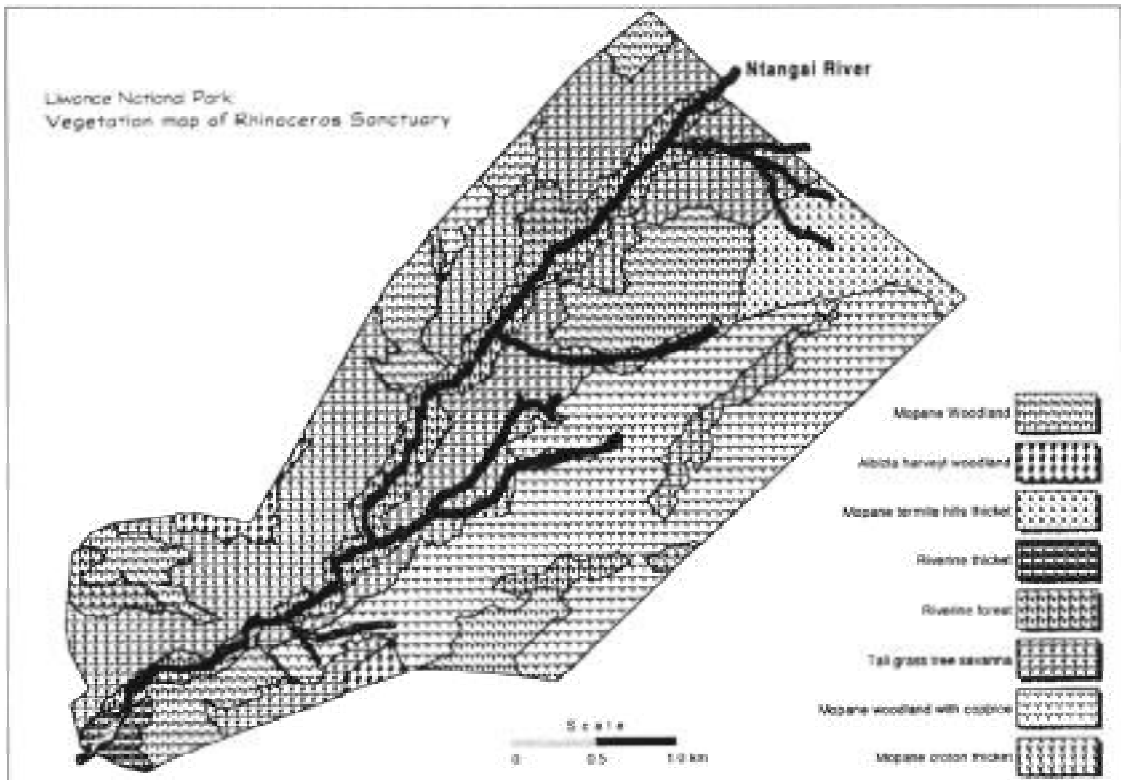

Figure 2 Vegetation map of the rhino sanctuary in Liwonde National Park

A. harveyi woodland (1%) and *mopane* clump savanna (9%). The second most dominant community is the tall, grass-tree savanna, which covers 35% of the sanctuary. At the edges of this community, the woodland is actively invasive and small, fire-coppiced woody plants are numerous. This may prove, ultimately, to be the most important area for rhino browse. The third community is the riverine forest/thicket covering 10% of the sanctuary. Where this community has few trees, a second variant, riverine thicket, is delineated (1%).

Observations in the bomas

At Kruger, the male rhino was watched for 18 days while the female, who was captured a few days after the male, was observed for 11 days. At Liwonde, both rhinos were observed for 47 days in the boma (27 October - 22 December 1993). There was no statistically significant difference in posture recordings (time spent standing or lying down) between Kruger and Liwonde for either animal.

There was a statistically significant difference in the behaviour of the female in the two sites ($c^2=11.51$, $df=3$, $p<0.1$). She was calmer in Liwonde than at

Kruger. The male, however, was calm and alert at both sites. Neither of the animals was aggressive or depressed. The general body condition of the male (as observed from the rib region) improved significantly in Liwonde ($c^2=9.1$, $df=2$, $p<0.1$).

All other conditions (defaecation, urination, appetite) appeared normal at both sites and were not tested statistically. There was no sign of reproductive behaviour.

Movements, habitat preferences and food selection in the sanctuary

The rhinos were released from the bomas in Liwonde on 21 and 22 December 1993. After an initial period of being solitary, they were first seen together on 16 January 1994 and have remained together ever since. Their movements are illustrated in Figure 3, and can be described as follows:

January-March (after release from the bomas)

They walked frequently up and down the sides of the Ntangai River and its two major tributaries. They were often seen resting in the southern section near the

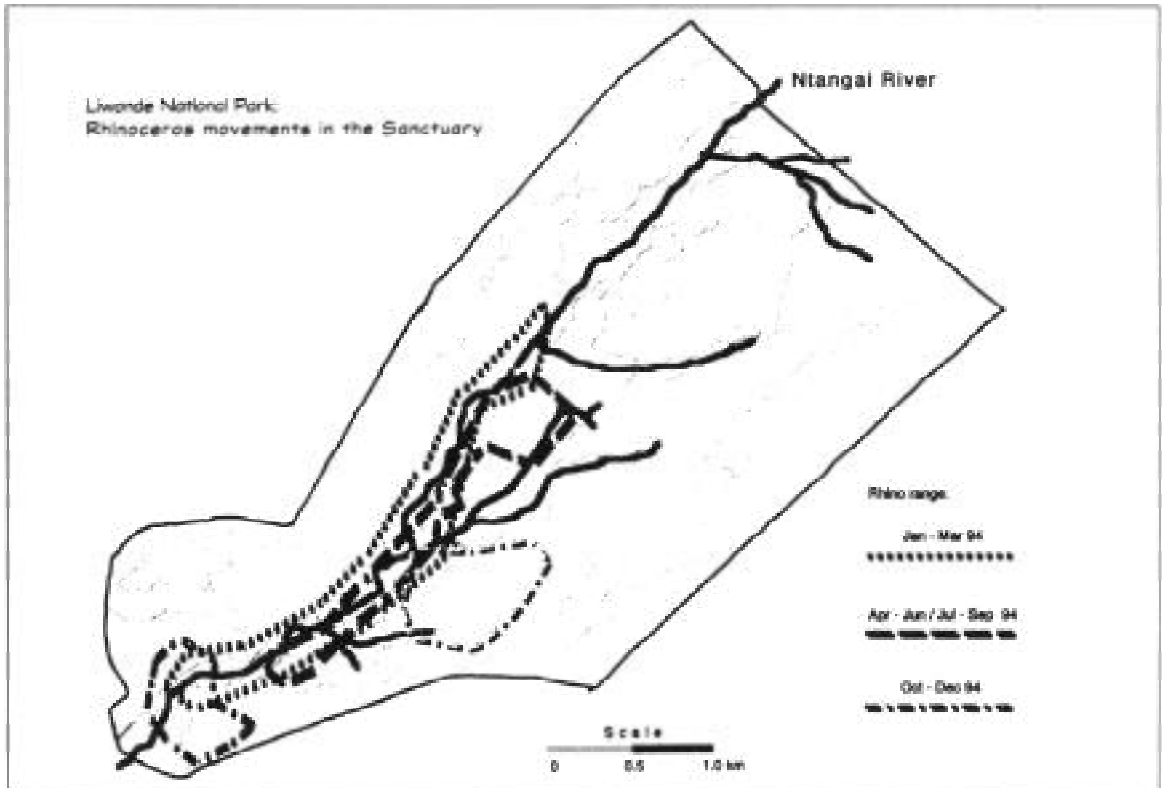

Figure 3. Rhino movements and range in the rhino sanctuary

bomas. Their range averaged approximately four square kilometres.

April-June

They were always seen together. Their activities were concentrated in the south-east and sometimes in the central area of the sanctuary. Their movements up and down the river banks continued and their range averaged at 3.5-4km².

July-September

At the end of July all the natural water pools dried up. The rhinos moved in the same general pattern as in the previous three months. There were no signs of the rhinos drinking at the artificial water hole throughout this period. They knocked down and fed

on *Euphorbia ingens* in the western area of the sanctuary.

October-December

Most of the rhinos' activity was concentrated along the Ntangai River. They were seen occasionally in the south and north of the sanctuary. They continued to knock down large numbers of *E. ingens*.

The adapted PIs for each vegetation type in the sanctuary are given in Table I. The calculations indicate that the *mopane-Croton* thicket, the *A. harveyi* woodland, the riverine thicket and the riverine forest, were the most preferred habitat types for the rhinos. All these areas occupy small proportions of the sanctuary.

Table 1. Vegetation communities in the rhino sanctuary showing the proportion of sanctuary area, with rhino frequencies observed in each community and the calculated preference index (PI) for each community.

Vegetation Community Type	Proportion of sanctuary	Number of times rhino seen	Proportion of count	Preference index
1. Riverine forest	0.09	8	0.1026	0.122
2. Tall grass tree savanna	0.35	15	0.1923	- 0.451
3. <i>Albizzia harveyii</i> woodland	0.011	7	0.0897	0.988
4. Mopane- <i>Croton</i> thicket	0.001	7	0.0897	0.989
5. Riverine thicket	0.01	6	0.077	0.870
6. <i>Mopane</i> woodland with coppice	0.45	33	0.423	- 0.060
7. <i>Mopane</i> termite hill thicket	0.09	2	0.423	0.715

Plant species eaten

There are 40 species of woody plants from 18 families which have so far been selected by the rhinos, as listed in Table 2. Woody species which were eaten

throughout the year were *A. nigrescens*, *A. sp.*, *C. mopane*, *Combretum fragrans*, *E. ingens* and *Ziziphus mucronata*. In the drier half of the year, *D. melanoxylon* was eaten in large quantities.

Table 2 Plant species eaten by rhinos in the sanctuary during their first year in Liwonde, in four periods: January to March (J-M), April to June (A-J), July to September (J-S) and October to December (O-D). The list for J-M includes plants which were eaten in the Liwonde bomas.

Plant species eaten under each family	Period of year			
	J-M	A-J	J-S	O-D
Annonaceae	*			
<i>Anisotes formosissimus</i>	*	*		
<i>Cleistochlamys kirkii</i>	*			
<i>Friesodielsia obovata</i>				
Asclepiadaceae				
<i>Fockea multiflora</i>				*
Apocynaceae				
<i>Strophanthus nicholsonii</i>			*	
Burseraceae				
<i>Commiphora africana</i>	*			
Caesalpinoideae				
<i>Cassia abbreviata</i>	*			
<i>Colophospermum mopane</i>	*	*	*	*
Capparidaceae				
<i>Capparis tomentosa</i>	*			
<i>Thilachium africanum</i>	*			
Combretaceae				
<i>Combretum apiculatum</i>				*
<i>Combretum fragrans</i>	*	*	*	*
<i>Combretum imberbe</i>	*	*		
<i>Combretum mossambicense</i>	*			
<i>Terminalia stenostachya</i>	*			
Euphorbiaceae				
<i>Croton gratissimus</i>	*			
<i>Croton megalobotrys</i>	*	*		

Table 2(contd.)

	J-M	A-J	J-S	O-D
<i>Euphoiphia ingens</i>	*	*	*	*
<i>Phyllanthus reticulatus</i>	*			
Malvaceae				
<i>Azanza garckeana</i>	*		*	
Mimosaceae				
<i>Acacia sp.</i>	*	*	*	*
<i>Acacia nigrescens</i>	*	*	*	*
<i>Acacia polyacantha</i>	*			
<i>Acacia xanthophloea</i>	*			
<i>Albizia anthemintica</i>	*			
Fabaceae				
<i>Dalbergia boehmii</i>	*			
<i>Dalbergia melanoxylon</i>			*	*
<i>Lonchocarpus capassa</i>	*			
<i>Melletia usaramensis</i>	*			
<i>Pericopsis angolensis</i>	*	*		
Rhamnaceae				
<i>Ziziphus mucronata</i>	*	*	*	*
Rubiaceae				
<i>Canthium frangula</i>				*
<i>Crossopteryx febrifuga</i>	*			
<i>Xeromphis obovata</i>				*
Salvadoraceae				
<i>Salvadora persica</i>	*			
Sapindaceae				
<i>Lecaniodiscus fraxinifolius</i>	*			
Solanaceae				
<i>Solanum incanum</i>	*			
Tiliaceae				
<i>Grewia bicolor</i>		*		
<i>Grewia monticola</i>				*
<i>Grewia stoltzii</i>				*

DISCUSSION

The potential for additional rhino introductions can be assessed in the sanctuary because the vegetation communities in the sanctuary represent some of the major communities of the Park, with the notable exception of the *Typha* and *Phragmites* swamps, the floodplain/grasslands and the mixed woodlands of the hills. The *mopane* complex communities, which occupy the biggest proportion of the sanctuary (55%) are more dominant in the Park itself (74%), while the tall grass-tree savanna occupies about twice the area in the sanctuary as in the Park. In spite of the differences in these proportions, the sanctuary is still representative of the Park's woodland communities. This is important from a management point of view, because the success or failure of rhino survival in the sanctuary may reflect the future survival of rhinos in the Park.

Observations in the bomas indicated that the rhinos were well adapted to the Liwonde environment by the time they were released into the sanctuary. The lack of reproductive signs was expected because the animals had not yet reached sexual maturity. Most researchers agree that sexual maturity in the black rhino is attained at about seven years of age for females and eight years in bulls (Bertschinger, 1994). The two rhinos in Liwonde are now sexually mature and the female shows signs of being pregnant.

The initial movements of the rhinos after their release from the bomas seemed to be exploratory. They may have been looking for the most suitable habitat. Their average range of approximately four square kilometres is similar to that of rhinos in Hluhluwe, (1.7-4.2km²) and Andries Vosloo (0.5-2.0km²) in South Africa (Adcock, 1994).

The habitats preferred by the rhinos all occupy minor proportions of the sanctuary. However, this interpretation is based on a very limited number of observations and is only indicative of true preference. Despite this, the results bear some similarity to observations made by Emslie & Adcock (1994) in Hluhluwe-Umfolozi National Park in South Africa where dense, riverine forest was the most preferred rhino habitat. Riverine forest/thicket was also preferred by the rhinos in Liwonde. Emslie & Adcock (1994) also reported that very tall grassy areas were rejected by rhinos, which seemed to be the case in the sanctuary too.

The application of an adapted PI formula to this data worked well. However, more observations need to

be included from vegetation communities which occupy larger proportions of the sanctuary in order to establish the validity of the PIs for the sanctuary.

Although 40 species of plants are listed as being eaten by the rhinos, the number will probably increase substantially, particularly when herbacious species are recorded and when observations intensify. Smithers (1983) stated that over 200 plant species are eaten by the black rhino, while Goddard (1970) recorded 102 species eaten in Tsavo National Park, Kenya. However, Emslie & Adcock (1994) found that only a few woody species (about ten) account for the bulk of the black rhino's diet. In Liwonde, six "key" species were utilised throughout the year, namely *C. mopane*, *A. nigrescens*, *A. sp.*, *E. ingens*, *C. fragrans* and *Z mucronata*.

Emslie & Adcock (1994) noted that plants with a high moisture content, such as leguminous plants and species in the Euphorbiaceae family, are important dietary items for black rhinos. Both Goddard (1968) and Loutit *et al.* (1987) specified that the *Euphorbia* was an important food item and that *Euphorbia* species, along with other succulent plant species, provide rhinos with water in the absence of free water. These findings seem consistent with those of the Liwonde sanctuary study, from which it was noted that ten leguminous species, four *Euphorbia* species and one species each from the Asclepiadaceae and Apolynaceae families, were among the list of browsed species.

We believe that *E. ingens* played an important role in providing moisture during the late dry season in 1994. This woody plant is filled with a white latex fluid which is toxic to some animals but does not seem to harm the rhino. The rhinos began to feed on the *E. ingens* very soon after their release from the boma and have caused major destruction of the species over the last 16 months. In the western half of the sanctuary, where *E. ingens* is very common, all the *E. ingens* less than 17cm in diameter in the monitoring plots have been destroyed. The feeding is wasteful, as the rhinos usually push the plants over and feed on the stems lying on the ground. Plants over 20cm in basal diameter are probably safe from being pushed over. There was a noticeable increase in the amount of woody parts from *Euphorbia* species found in rhino dung in the late dry season.

Fockea multiflora, a large, latex-filled liana, also showed signs of being fed upon heavily as the dry season progressed in 1994. Some of these plants have had most of their basal stems eaten away by rhinos.

However, none of them has died so far due to damage. Hall-Martin *et al.* (1982) reported that *F. edulis* was eaten by rhinos in Addo National Park, South Africa.

While the two rhinos in Liwonde were able to survive comfortably throughout the long dry season, presumably due to feeding on succulent plants, this does pose a problem for any future rhino introductions into the sanctuary. Artificial water holes will be needed if the succulent plants become too few.

ACKNOWLEDGEMENTS

The rhino introductions were made possible by the generous assistance of the South African government through the Malawi/South Africa Wildlife Project, the J and B Distilleries "Care for the Rare" programme (UK), the J and B Circle (Malawi) and the South African Air Force, which transported the rhinos to Malawi. We would like to thank the Parks and Wildlife Research Assistant, E. Sichali, and Research Scouts, A. Gausi, J. Mtima and C. Engelesi, for their dedication during data collection. We thank Central African Wilderness Safaris for their hospitality and for providing accommodation and general help to C. Dudley while in the Park. Thanks are also due to Dr. F. non Roene, the GTZ Technical Adviser at Liwonde Hospital, for allowing us access to the computer to draw the sanctuary maps. Finally, our thanks to the Director, National Parks and Wildlife, for granting permission to publish this paper and to Mrs. Bhima for typing the final manuscript.

REFERENCES

Adcock, K. (1994) The relevance of territorial behaviour in black rhino to their population management. In: *Proceedings of a Symposium on Rhinos as Game Ranch Animals*. Ed: B.L. Penzhorn & N.P.J. Kriek. Onderstepoort, South Africa. pp 65-81.

Ansell, W.F.H. & R.Z. Dowsett (1988) *Mammals of Malawi. An Annotated Checklist and Atlas*. The Trendline Press, Zennor, St Ives, Cornwall.

Bertschinger, H.J. (1994) Reproduction in black and white rhinos: a review. In: *Proceedings of a Symposium of Rhinos as Game Ranch Animals*. Ed: B.L. Penzhorn & N.P.J. Kriek. Onderstepoort, South Africa. pp 155-161.

Dudley, C.O. (1994) The flora of Liwonde National Park, Malawi. In: *Proceedings of the XIIIth Plenary Meeting of AETFAT, Zomba, Malawi*. Ed: J. Seyani & A.Chikuni. Vol. 2. 1485-1509.

Dudley, C.O. & Stead, D. (1977) Liwonde National Park - Part II: the mammals. *Nyala* 3, 29-38.

Emslie, R.H. & Adcock, K. (1994) Feeding ecology of black rhinos. In: *Proceedings of a Symposium of Rhinos as Game Ranch Animals*. Ed: B.L. Penzhorn & N.P.J. Kriek. Onderstepoort, South Africa. pp 65-81

Goddard, J. (1968) Food preference of two black rhinos. *E. Afr. Wildl.J.* 6, 1-18.

Goddard, J. (1970) Food preference of black rhinoceros in the Tsavo National Park. *E. Afr. Wildl. J.* 8, 145-162.

Hall-Martin, A.J. (1982) Seasonal variation of diet and faeces composition of black rhinoceros, *Diceros bicornis*, in the Addo Elephant National Park. *Koedoe* 25, 63-82.

Loutit, B.D., Louw, G.N. & Seely, M.K. (1987) First approximation of food preferences and the chemical composition of the diet of the desert-dwelling black rhinoceros, *Diceros bicornis* L. *Mado qua* 15, 35-54.

Pienaar, D.J., Bothma, J. du P. & Theron, G.K. (1992) Landscape preferences of the white rhinoceros in the southern Kruger National Park. *Koedoe* 35, 1-8.

Smithers, R.H.N. (1983) *The Mammals of Southern Africa Sub-region*. University of Pretoria, Pretoria.

ULTRASONOGRAPHY AS A TOOL IN THE CONSERVATION OF THE AFRICAN RHINOCEROS: *ex situ* and *in situ* applications

Robin W. Radcliffe, Meg P. Bommarito and Steven A. OSofsky

Fossil Rim Wildlife Center, PO Box 2189, RT.1 Box 210, Glen Rose, TX 76043, USA

INTRODUCTION

With a demand for horn that is difficult to reduce and ongoing land-use conflict in natural habitats, all species of the rhinoceros remain under threat in the wild - some more critically than others. While the southern white rhino (*Ceratotherium simum simum*) appears relatively stable, with more than 6,000 animals (Walker, 1994), the black rhino (*Diceros bicornis*) has not fared well. Black rhinos have declined by at least 95% in the past twenty years, even by conservative estimates (Walker, 1994; Potter, 1994). While each rhino species faces its own set of problems, managers of wildlife reserves and zoological parks are working with incomplete knowledge regarding normal rhinoceros reproductive biology, information which is fundamental to successful propagation efforts. While African rhinos have been the focus of our research to date and are the subject of this paper, many of the concepts discussed below could potentially be extrapolated to conservation programmes focused on Asian species.

Captive breeding programmes, conceptually designed as insurance policies for African rhino species, have, for the most part, yet to meet their objectives regarding minimal loss of genetic diversity and, at least, replacement-level reproduction (Foose, 1992). While white rhinos survive well in captive settings, overall breeding efficiency appears to be stagnant. Without intervention, many of the founder animals in the captive southern white rhinoceros population will not have reproduced before they die. These genetically valuable animals are probably nearing the end of their reproductive lives. The northern subspecies of the white rhinoceros (*Ceratotherium simum cottoni*) is in a precarious state because of the low number of individuals in its isolated native habitat in Zaire's Garamba National Park (Smith & Smith, 1993), as well as lack of expansion in the captive population. The black rhinoceros has suffered serious losses at the hands of poachers and is being isolated into smaller and smaller protected areas in Africa, with *ex situ* captive populations plagued by a variety of diseases with multi-

factorial aetiologies that appear to be related to captivity itself (Miller, 1994).

Ultrasonography is a tool being applied to captive management to resolve some of the basic mysteries surrounding rhinoceros reproduction. Decisions about managed breeding can finally be based on objective reproductive assessment of individual animals instead of on conjecture. This technology can also be taken into the field where it could provide valuable information about the reproductive functioning of wild rhinos as well. At its most basic level, ultrasonography, at the time of rhino capture, could provide insights into the effects of translocation on embryo/foetal viability during different stages of gestation. For an animal producing one offspring at a time with a long inter-birth interval, this information could prove valuable, considering that rhinos are, by necessity, being more intensively managed in parks, reserves, conservancies, sanctuaries and protection zones throughout Africa.

CASE STUDY

An approximately 12-year-old female southern black rhinoceros (*Diceros bicornis minor*) was captured in Zimbabwe, held in a boma for several months, and then transferred to the Fossil Rim Wildlife Center in Texas, USA, in April 1992. On arrival at Fossil Rim, she was aggressive in nature and remained apprehensive in the presence of humans. In January 1995, a full-time caretaker began intensive conditioning of the rhino to allow hands-on examinations in the hope of eventually performing transrectal, ultrasound evaluations without sedation. The conditioning process involved exposing the female to long hours of human contact along with visual, tactile and auditory stimuli, including the intermittent playing of a radio to add background noise to her normal environment.

The positive conditioning process began with providing food, such as apples and sweet potatoes, as a reward for tolerating the proximity of people.

This soon expanded to the application of human touch on different areas of the rhino's body at the time of feeding. Over a period of several months, the rhino began to trust her human caretakers enough to facilitate twice-daily examination and treatment of a potentially serious hoof crack. The conditioning process was facilitated by

the use of a "free-stall" chute that was designed to allow the rhino to choose its own response to the process (Radcliffe *et al.*, 1995). The rhino was never restrained physically or chemically for the purposes of conditioning, examination, or treatment. Diagrams of the chute design are provided in Figures 1 and 2.

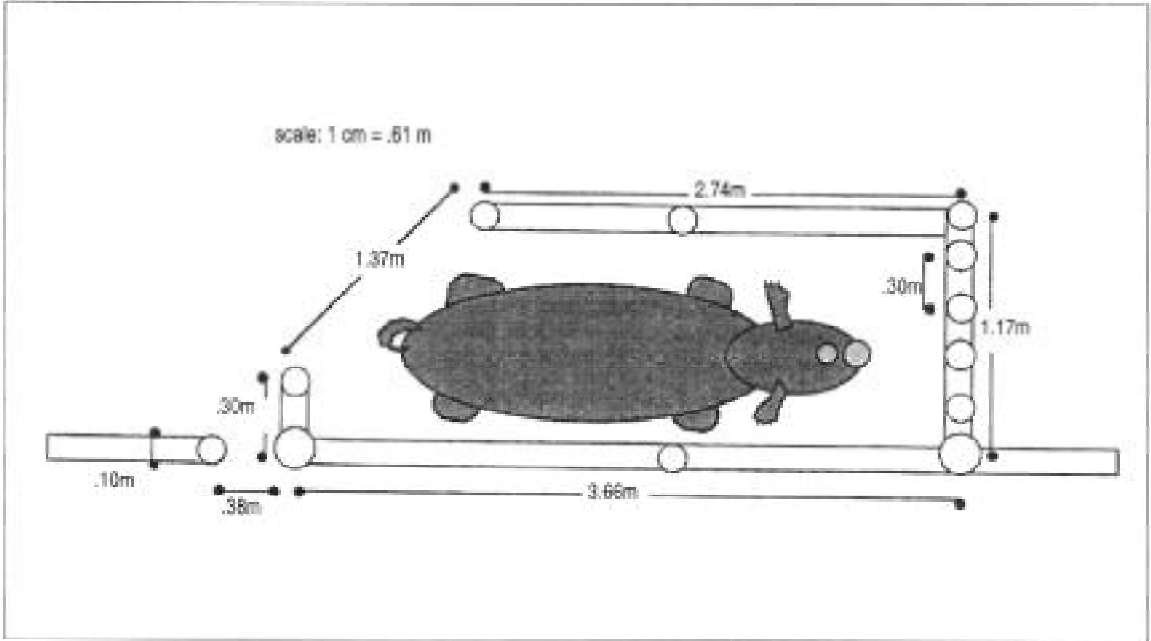

Figure 1. Black rhino in "free-stall" chute. top view.

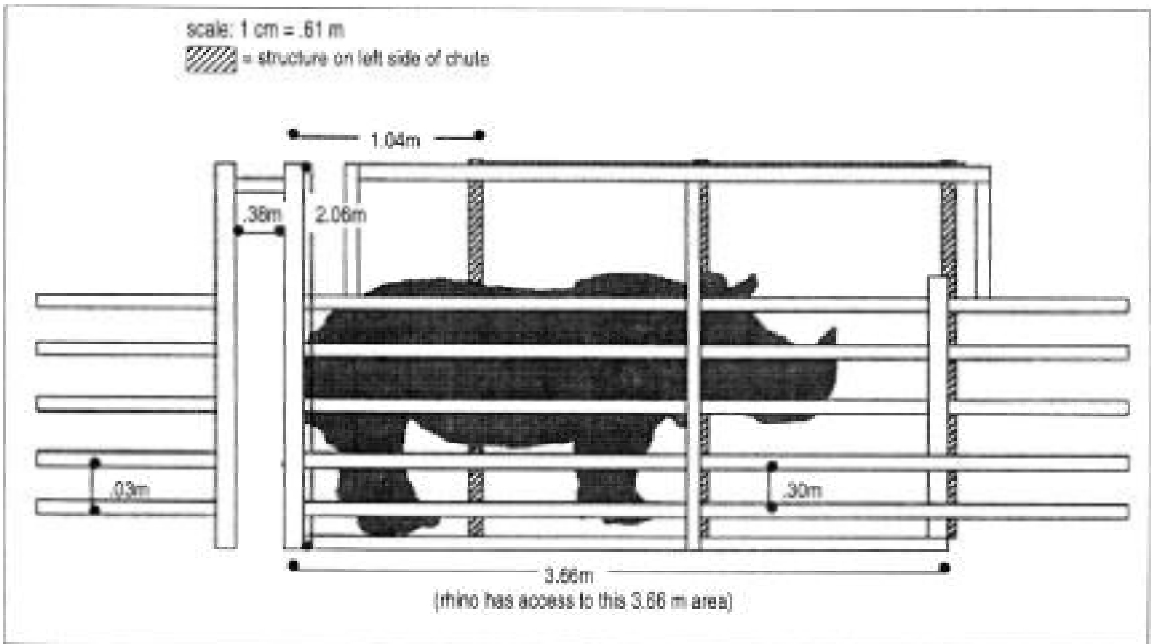

Figure 2. Black rhino in "free-stall" chute, right side view.

Starting in July 1995, the female was exposed to daily rectal examination in the chute without chemical restraint. Within two weeks, the application of transrectal ultrasound was successful, again without sedation. The foetal, ultrasonographic images obtained, correlated well with a breeding date approximately 11 months earlier. Important anatomical features of the rhino foetus can be visualised in Figures 3 and 4. The foetal skull can be observed as an echogenic (white structure) on ultrasound. The head is facing to the left and several structures can be identified from the ultrasound image. The foetal eye (bony orbit) is located to the far right and appears non-echogenic, or as a black circle. The bony protuberance that supports the horn bud of the developing rhinoceros can be seen as a bump on the tip of the nasal portion of the skull. The amniotic membrane appears as an echogenic line just dorsal to the skull and within the foetal fluids. The molars are very echogenic and can be observed in sagittal sections through the foetal skull, as illustrated in Figures 3 and 4. If sufficient data were collected to document and chart foetal dimensions, such as eye diameter or skull length, as has been done in the horse (Ginther, 1995), gestational age charts could be developed for the rhino.

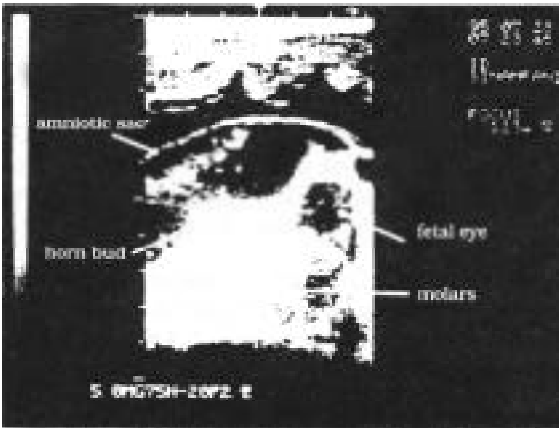

Figure 3. Transrectal ultrasonographic image of the head of a late-term southern black rhinoceros foetus illustrating identifiable structures, oblique sagittal view. All foetal images were obtained with an ALOKA 500V ultrasound unit using a MHz linear array transducer.

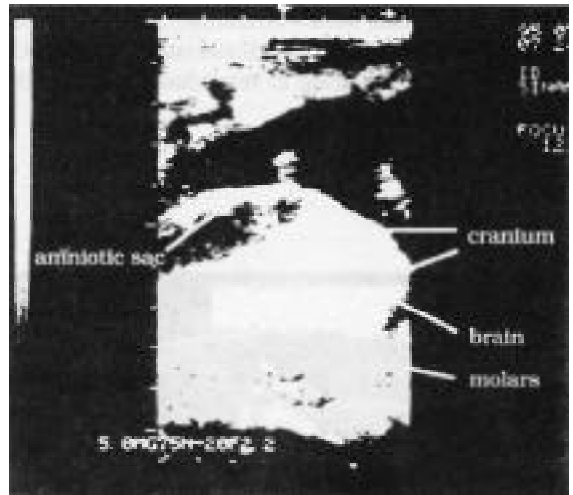

Figure 4. Transrectal ultrasonographic image of the head of a late-term black rhinoceros foetus, mid-sagittal view.

DISCUSSION

The potential applications of transrectal ultrasound in large, non-domestic animals, have been recognised recently (Adams *et al.*, 1991). The management implications of this work are obvious with regard to captive rhinoceros propagation. In this case, a decision to postpone immobilisation of the female for more aggressive treatment of the hoof crack was based partly on ultrasonographic confirmation of late-term pregnancy. Furthermore, the conditioning process not only allowed for the transrectal ultrasound examinations, but enabled successful treatment and monitoring of the hoof problem in a previously intractable rhino.

This same technology has also been used to elucidate the oestrous cycle of one of Fossil Rim's southern white rhinoceros females (cycle length approximately 35 days), as well as to document early embryonic loss in one female. The latter is believed to have been caused by an uterine infection and, like endometritis in the horse, was characterised by intrauterine fluid collections in late di-oestrous. Pregnancies as early as 15 days have been detected in Fossil Rim white rhinos using transrectal ultrasound. An early black rhino pregnancy has also been detected (Figure 5). Fertility problems are certainly bound to be more prevalent in captive situations than in the wild:

information gleaned from wild animals could help zoos to identify environmental, social and nutritional factors that may be contributing to reproductive failure in captivity.

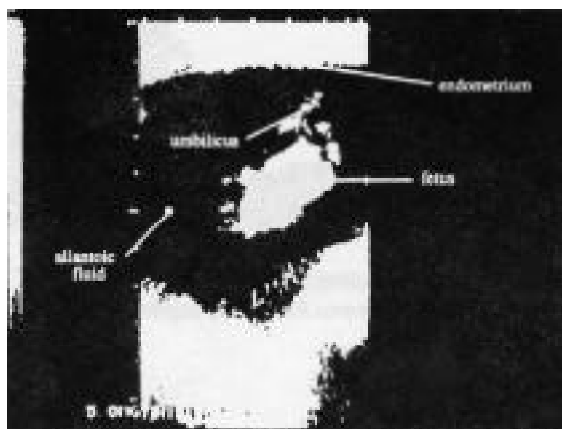

Figure 5 Black rhinoceros foetus, estimated at 50-60 days old

The application of this work in rhino range states remains open to debate. The stresses associated with immobilisation, transport and boma confinement, can result in abortion in a wide variety of species, including rhinos; the detection of an embryo/foetus could potentially change the course of management during boma confinement or during translocation. Data collected from scanning females in the field could also provide managers with a measure of a rhino population's reproductive health. This would facilitate sound management decisions, enabling the differentiation between populations which could sustain translocation of individuals to other areas, and those requiring more intensive conservation efforts.

Detecting the stage of an oestrous cycle of a female rhino on one examination would be difficult, but this has been done in the horse based on size and echogenicity of the corpus luteum (Ginther, 1986). Since both the rhinoceros and the horse, as perissodactylids, share a common evolutionary history, it seems reasonable to look for similarities in their reproductive biology as part of ongoing research efforts.

CONCLUSIONS

The utilisation of transrectal ultrasonography for research and for management of captive black and white rhinoceros has been beneficial in elucidating normal and abnormal reproductive functioning in female rhinos without sedation. The authors are not suggesting that wild rhinos should be subjected to immobilisation simply to be scanned by ultrasound. This would be an inappropriate use of financial and technological resources in most contexts. It may, however, be worth integrating a 10-15 minute scanning procedure into some capture and translocation protocols which are already in place, for a variety of reasons. By scanning rhinos opportunistically, managers of free-ranging rhinos may obtain practical information, while simultaneously enhancing their understanding of the causes of infertility in captive specimens. The selective application of transrectal ultrasonography could help to shape management decisions that underline the maintenance of healthy conservation units both *in situ* and *ex situ*.

ACKNOWLEDGEMENTS

The authors would like to thank Fossil Wildlife Center and Rhino Care Specialist Adam Eyres, the International Rhino Foundation, and ABC/Kane Productions for supporting this project. We would also like to acknowledge Chuck Boland of Aloka for generous contributions of ultrasound equipment.

REFERENCES

- Adams, G.P., Plotka, E.D., Asa, C.S. & Ginther, O.J. (1991) Feasibility of characterizing reproductive events in large nondomestic species by transrectal ultrasonic imaging. *Zoo Biol.* 10,247-259.
- Foose, T.J. (1992) Overview of captive programs for rhinos. In: *Rhino Global Captive Action Plan Workshop Briefing Book, Section 2*. London, United Kingdom, 9-10 May 1992. Edited by T.J. Foose.
- Ginther, O.J. (1986) *Ultrasonic Imaging and Reproductive Events in the Mare*. Equiservices Publishing, Cross Plains, Wisconsin, USA.
- Ginther, O.J. (1995) *Ultrasonic Imaging and Animal Reproduction: Horses, Book 2*. Equiservices Publishing, Cross Plains, Wisconsin, USA.
- Miller, R.E. (1994) Diseases of black rhinoceroses in captivity. In: *Proceedings of a Symposium of Rhinos as*

Game Ranch Animals. Onderstepoort, Republic of South Africa, 9-10 September 1994. pp 25-30. Edited by B.L. Penzhorn & N.P.J. Kriek.

Radcliffe, R.W., Osofsky, S.A. & Eyres, A.I. (1995) Design and applications of a "free-stall" chute for passive restraint of the non-sedated white rhinoceros (*Ceratotherium simum simum*). In: *Proceedings of the American Association of Zoo Veterinarians! Wildlife Disease Association/American Association of Wildlife Veterinarians*. East Lansing, Michigan, USA, 12-17 August 1995. pp 430-434. Edited by R.E. Junge.

Smith, K. & Smith, F. (1993) Conserving rhinos in Garamba National Park. In: *Rhinoceros Biology and Conservation: Proceedings of the First International Conference*. San Diego, California, USA, 9-11 May 1991. pp 166-177. Edited by O.A. Ryder.

Walker, C.H. (1994) Rhinos in Africa - the present situation. In: *Proceedings of a Symposium on Rhinos as Game Ranch Animals*. Onderstepoort, Republic of South Africa, 9-10 September 1994. pp 1-3. Edited by B.L. Penzhorn & N.P.J. Kriek.

Photo credit: Robin Radcliffe

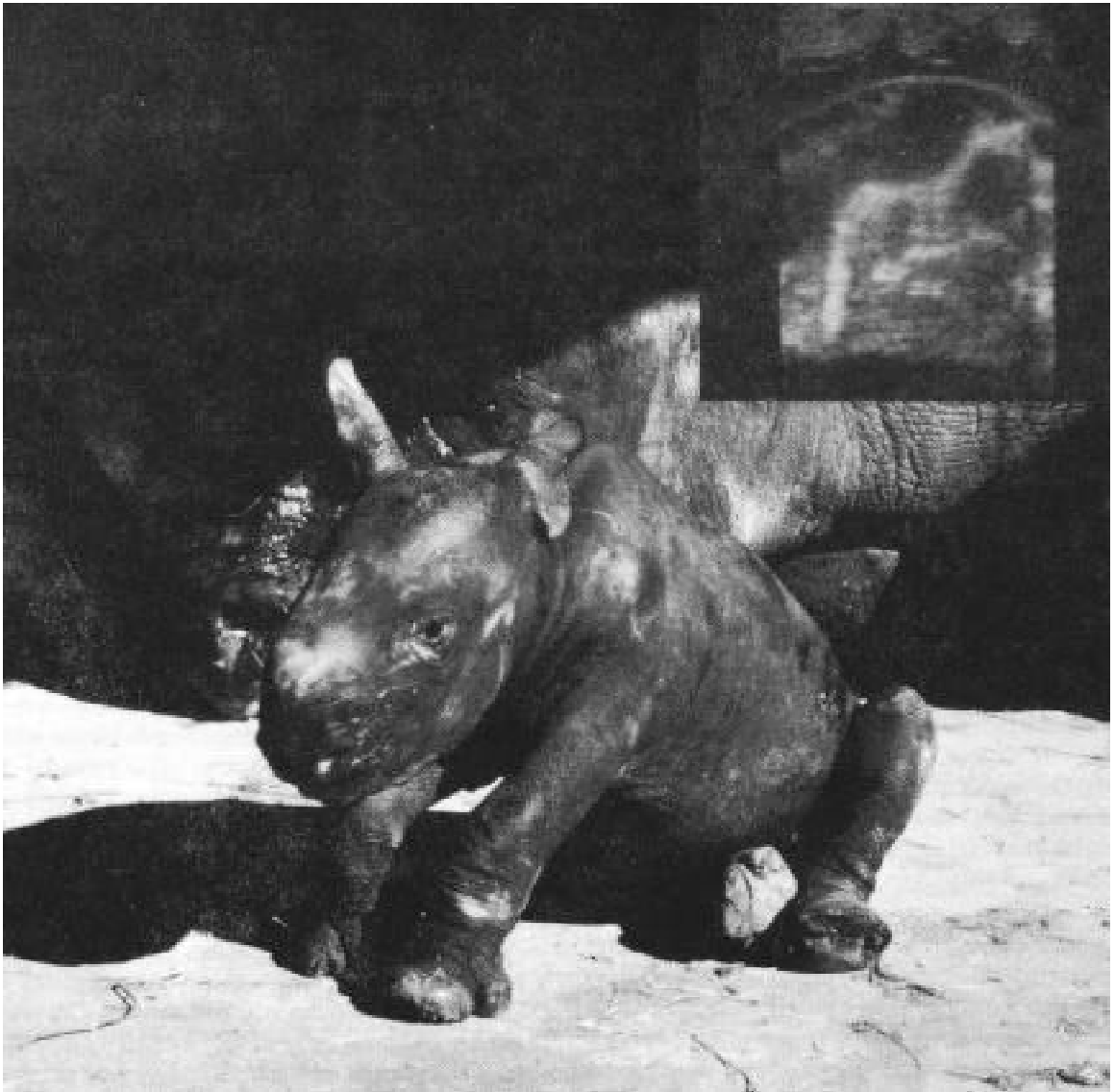

A one-week-old southern black rhino calf recently born as a result of captive breeding efforts at the Fossil Rim Wildlife Center in Texas, USA. The inset shows an ultrasound picture of the calf as a foetus.

IS RHINO DEHORNING SCIENTIFICALLY PRUDENT?

Joel Berger¹ and Carol Cunningham²

¹Programme in Ecology, Evolution and Conservation Biology

²Department of Environmental and Resource Sciences

University of Nevada (MS-186), Reno, Nevada 89512, USA

Field address (from February 1996 until July 1997): PO Box 142, Moose, Wyoming 83012, USA

ABSTRACT

We contrasted calf survivorship of horned and dehorned black rhino (*Diceros bicornis*) females in the Namib Desert, and have reported elsewhere that calf mortality was higher in a dehorned population sympatric with spotted hyaenas (*Crocuta crocuta*) than it was in a hyaena-free area or where mothers were horned. Our findings have been controversial because sample sizes are small and data on some ecological variables were not offered. Here, we clarify our research protocols and substantiate prior findings with comparative data on potentially confounding variables such as horn size similarities, hyaena abundance, patterns of precipitation, herbivore biomass, the location of domestic stock, and adult rhino mortalities. We suggest that management decisions based on empirically-derived data might be better than those based on no data at all.

INTRODUCTION

Over the last three decades, populations of black rhinos (*Diceros bicornis*) have dropped nearly 97%, so strategies aimed at preventing extinction have required emergency action (Western, 1987; Leader-Williams, 1993). One such tactic has been dehorning, a programme debated in Kenya nearly 15 years ago (Western, 1982) and first tried in Namibia in 1989 because funds for anti-poaching patrols were limited (Lindeque, 1990).

Previously, we suggested that when dehorned mothers were sympatric with spotted hyaenas (*Crocuta crocuta*) in the Namib Desert, fewer calves were recruited than in the absence of hyaenas. We also pointed out that drought was likely to have exacerbated these effects and that our sample of 10 calves was small (Berger & Cunningham, 1994a,b). Our findings have been challenged by government and non-government officials in Namibia (Loutit & Montgomery, 1994a,b;

Lindeque & Erb, 1995). Here we present new data and summarise previous findings to clarify and substantiate our position. As before (Berger *et al.*, 1994), we do not take issue with the possibility that government horn harvesting might reduce poaching pressure on rhinos. What we are concerned with are biological issues concerning dehorning and data as they relate to management decisions. Lindeque and Erb (1995) raised issues ranging from statistics and data interpretation, topics critical to any scientific assessment. We address their claims in three sections: research methodology and hyaena abundance; factual errors; and evaluation of confounding variables. We close by addressing the public interest and suggesting why independent research is in the best interest of conservation.

RESEARCH METHODOLOGY AND HYAENA ABUNDANCE

Study design

Our research was aimed at assessing components of rhino social biology, including calf survival, and involved a three-way comparison of contiguously-distributed rhinos in the northern Namib Desert with contrasts among: 1) horned rhinos in the presence of dangerous predators (lions, *Panthera leo*, and spotted hyaenas); 2) dehorned rhinos in the absence of dangerous predators; and 3) dehorned rhinos in the presence of spotted hyaenas. The fourth category, horned rhinos in the absence of predators, does not presently occur in the Namib Desert. Of course, having a fourth study area fulfills the requirements of a balanced study design because calf survival may vary randomly and knowledge of calf mortality under all conditions is clearly relevant. Nevertheless, it seemed reasonable to forgo information from sites where predators are absent and rhinos horned because of the presumption that without predators calf survival should not change.

Abundance of spotted hyaenas

Lindeque and Erb (1995) suggest that our study design was flawed because spotted hyaenas occur throughout the study region. Support for their claim is unbalanced. They fail to cite Skinner and van Aarde (1981) who surveyed the Namib Desert for brown (*Hyaena brunnea*) and spotted hyaenas and reported “we still have no idea what numbers occur in the area or ... range”. Instead, they cite Skinner & Smithers (1990) although these authors provide range maps only and not data of the resolution needed to distinguish among our three respective study regions. Additionally, the use of unpublished records to bolster their argument is questionable because it is impossible to decide how credible the records are.

Lindeque and Erb (1995) reported spotted hyaenas at a rhino carcass in the Doros Crater (DC) area. They were fortunate in their observation because, on average, spotted hyaenas in the northern Kalahari spent less than six minutes on a carcass (Cooper, 1990), yet the Namib Desert rhino in question had been dead for about three weeks when discovered (Morkel, 1992). Lindeque and Erb (1995) also imply that it is difficult to distinguish between the tracks of

spotted and brown hyaenas. However, both Damara herdsmen in the Namib Desert and !Xo trackers in the Kalahari can distinguish between the species because of “the relative difference in size between the front and back feet. In the brown hyaena the back feet are much smaller than the front feet, while in the spotted hyaena the difference is not nearly so marked” (Mills, pers.comm.; Liebenberg, 1990).

We evaluated hyaena abundance using standard methods employed in southern Africa, using counts of tracks crossing roads (Mills *et al.*, 1984). We recorded every possible hyaena spoor on roads and elsewhere. If Lindeque and Erb (1995) are correct that both species of hyaenas are widespread, then our inclusion of all hyaena signs would inflate the number of hyaenas irrespective of species. We also used more direct methods to distinguish between brown and spotted hyaenas. Vocalisations of spotted hyaenas were recorded nightly as either existing or absent. This approach is conservative because it discounts the possibility that more than one animal may be present or calling. We also recorded how many brown and spotted hyaenas were seen per day spent in the field (and by accounting for km/transect; see Table 1 and below for details) but, as above, groups were recorded as single observations.

Table 1. Mean length (km \pm SE.) of 126 transects and herbivore biomass (kg/km²) during wet and dry seasons in three census areas of the northern Namib Desert.

	North of the veterinary fence		Doros Crater		Springbok	
	Transect Length	Biomass	Transect Length	Biomass	Transect Length	Biomass
1991						
Wet	20 \pm 3(10)	65 \pm 20	44 \pm 5 (5)	44 \pm 8	36 \pm 10(4)	29 \pm 12
Dry	51 \pm 7 (5)	5 \pm 3	55 \pm 5(15)	35 \pm 8	30 \pm 3(5)	20 \pm 12
1992						
Wet	15 \pm 22(4)	64 \pm 30	48 \pm 4(3)	56 \pm 6	45 \pm 10(9)	57 \pm 41
Dry	57 \pm 15(5)	46 \pm 25	49 \pm 11 (4)	30 \pm 16	35 \pm 4(4)	15 \pm 8
1993						
wet	67 \pm 17(5)	106 \pm 78	35 \pm 5 (3)	114 \pm 80	39 \pm 13(13)	62 \pm 23
Dry	55 \pm 8(14)	25 \pm 9	16 \pm 2(12)	16 \pm 10	26 \pm 4(6)	12 \pm 4

Sample size in parentheses. Area sizes are NVF: 1,858km², DC: 3,418km²; SR: 1,710km²

At no site were brown hyaenas seen. Spotted hyaenas were noted at only two of our three study regions (see Figure). Irrespective of species, there was not a single track, vocalisation, or sighting in the DC area although transects there totalled more than 1,675km (Table 1). Similarly, there was no evidence of lions in the DC area. We therefore designated the site as predator-free. DC differed from the other two areas (vocalisations: G-Test for Independence, $G_{adj}=1.01$, $p<0.001$; a test for Homogeneity of Variance reveals that neither site with hyaenas differs from each other but both differ from the DC area; $p<0.001$). The frequency with which tracks were detected also varied among sites (Figure 1) (Kruskal Wallis Test, $H = 10.89$, $p<0.004$) with the DC area differing from the other two area ($p<0.01$).

FREQUENCY OF HYAENAS

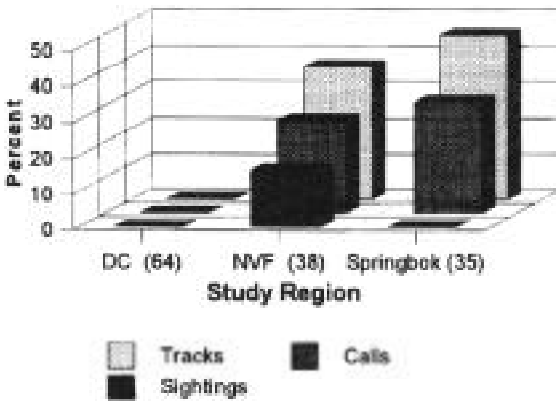

Figure. The proportion of transects (listed in Table 1) during which tracks and sightings, and calls (based on number of rights in parentheses) of hyaenas were noted. Sighting and calls are for spotted hyaenas.

Why spotted hyaenas were not seen at the Springbok River (SR) site although tracks and vocalisations were noted is easy to explain. We made no effort to observe them there. When hyaena-like calls emanated on multiple occasions next to our SR camps, we made no effort to verify that they were indeed made by hyaenas. We believe that we can discriminate the calls of spotted hyaenas from those of other mammals. Nevertheless, our other data, shown in the Figure, make clear that hyaena presence varied regionally and consistently during the period of our study and that one area was free of hyaenas and lions.

FACTUAL ERRORS

Drought

Lindeque and Erb (1995) suggest “the alleged rhino calf deaths coincided with the worst drought in human memory in Namibia”. We evaluated their claim in two ways using data on rainfall inside the study area (Wereldsend: =72 mm/yr; Owen-Smith, unpublished; $N=12$ years) and to the north (Sesfontein: $x=95$ mm/yr; Namibia Weather Bureau Statistics, Windhoek; $N=24$ years). First, we described the proportion of years in which less precipitation occurred than during the 1992-1993 wet season. Next, we asked what proportion of successive years received less rain than that recorded during the 1991-1992 and 1992-1993 period combined. Irrespective of the method used, we found no support for the claim that the drought when the calves disappeared was the worst. Data from Wereldsend and Sesfontein, respectively, indicate that on a per year basis, 33% and 21% of the years had less rainfall. On a multiple year basis, the proportions of periods with less rain were 25% and 17%. So, although conditions at our sites were drier than average, Lindeque and Erb (1995) cannot accurately state that “this” drought really was the worst in human memory.

Rhino mortalities

Lindeque and Erb (1995) purport that the SR site was drier than others. They cite a Normalised Difference Vegetation Index (unpublished data) and point to animals at that site being in poor condition. They also refer to the starvation of a sub-adult rhino. None of these is prime evidence for the SR animals being differentially affected than desert rhinos elsewhere.

If SR animals were in poorer condition, Lindeque and Erb (1995) might have a case. However, a previously published analysis shows otherwise (Berger *et al.*, 1994). Briefly, we used a one-way analysis of variance to determine whether mean body condition scores (pelvic, spinal, and rib prominence; as suggested for rhinos by Keep [1971]) varied among desert regions. If the SR rhinos were in the worst condition, their hypothesis would be supported. However, body condition did not differ among sites ($F_{2,9}=1.80$)(Berger *et al.*, 1994). Furthermore, Lindeque and Erb’s (1995) table incorrectly lists the site of the sub-adult mortality as SR. It was the DC region, correctly stated by Lindeque and Erb (1995) in the text.

Two adults died during 1992-1993 north of SR, our site with horned rhinos. Similarly, an adult male and calf died in the DC region in 1990. None of the deaths were included in Lindeque and Erb's (1995) table. Except for the calf mortality which involved poaching, the other three were apparently natural as horns were recovered at the site and there were no signs of bullets. Thus, mortalities were not confined to the SR site as implied by Lindeque and Erb (1995) but occurred in all study regions.

Lindeque and Erb (1995) rely on the data of Loutit to estimate calf births and deaths. However, Loutit's reports are contradictory, sometimes claiming one calf death or two (Loutit & Montgomery, 1994a,b). Furthermore, although Loutit and Montgomery claim that their records are continually updated, there was a three year period after the 1989 dehorning operation in which half of the remaining eight dehorned rhinos were identified incorrectly (Berger *et al.*, 1994). Thus, reliance on the unpublished records of Save the Rhino Trust (SRT) or those supplied by SRT to the Ministry appears imprudent if the goal is to understand local population structure and distribution.

Had Lindeque and Erb been aware of results of surveys carried out by their own Ministry biologists (DuPreez, unpublished), they would have confirmed our evidence of two births in the SR. Our subsequent report of two missing neonates stemmed from observations of mothers without young calves (Berger & Cunningham, 1994b). The third missing calf was surmised from further observations of a cow with an enlarged udder. In mammals as varied as cheetahs and caribou, the presence of swollen udders and absence of young has been used to gauge mortality (Laurenson, 1994; Cameron & Ver Hoef, 1994). We see no reason why rhinos should be different.

In support of this idea, we point out that the calfless female observed with a swollen udder in early 1993 gave birth in mid-1994 (Lindeque & Erb, 1995). Given a 16-month gestation period of a rhino and our observation of her, approximately 17 months before the estimated 1994 birth date, it seems likely that just after the calf was lost the mother recycled, was impregnated, and gave birth in mid-1994.

Number of dehorned rhinos

We believe Lindeque and Erb (1995) are mistaken about the number of dehorned rhinos. In 1989 there were 12, eight more in 1991, for a total of 20, not 28 as reported in their table.

Horn size, missing and maimed calves, and evolution

Lindeque and Erb (1995) argue that "horn dimensions *per se* are not that important for the protection of calves... (because)... these parameters would have evolved toward an optimal shape and length rather than varying to the degree seen in all populations" and suggest rhino horns show "extreme" variation under natural conditions. We have presented data elsewhere from four populations in which Lindeque was a co-author (Berger *et al.*, 1993) showing that coefficients of variation in horn size range from 31 to 62%. However, since horn length is significantly related to age in both sexes (Berger & Cunningham, 1995), it makes little sense to argue about the functional significance and optimal design of horns without controlling for age. It is incorrect to imply that just because a trait is variable the possibility of selection is relaxed (Barnard, 1991). With respect to the size of anterior horns of mothers, the fact remains that in areas with spotted hyaenas, mothers with surviving calves had anterior horns that were significantly longer ($X=40\text{cm}$, $N=4$) than mothers with regrowing horns whose calves disappeared ($X=23\text{cm}$; $N=3$) (Wilcoxon Test; $W = 22$; $p<0.029$).

It is also important to ask what, if any, evidence from other sites may suggest that horns are associated with calf protection. Lindeque (1990) made such an attempt and suggested a null hypothesis, that negative biological effects are not expected from dehorning, a decision "taken in the absence of strong evidence of likely detrimental effects" (Lindeque, 1990). Is the *a priori* assumption that predation may not affect horned rhinos or their calves reasonable? We believe a more thorough search of the literature and discussion with other researchers would have raised the alternative possibility - that predation affects calves - to a higher level of scrutiny.

The maiming of calves, defined here as ear or tail loss, was apparently not considered, nor was the possibility that calves that have died might not be detected. In support of dehorning, Lindeque (1990) claimed an association between calf recruitment and spotted hyaena density in Etosha, the implication (we presume) being that hyaenas do not affect calf survival. However, there are problems with this assertion. First, the rhino mothers are horned. If horns are a deterrent to potential predators, then one might not expect heightened calf mortality. Second, data are not offered on either hyaena densities or calf survival. If the alleged association exists, little may be concluded since calf mortality rates are

unknown as is potential prey biomass. Hyaenas may simply be feeding on more abundant and less formidable prey.

Nevertheless, maimed calves are known from the Aberdares (Kenya), Umfolozi (South Africa) and Etosha and the Kaokoveld (Namibia) (Berger & Cunningham, 1994c). At Namibia's Waterberg Plateau Park, where spotted hyaenas do not occur, maimed calves were not reported as of late 1993 (Erb, pers. comm.). It is now clear that spotted hyaenas have the potential to maim calves: a regression analysis of the association between the proportion of maimed calves to spotted hyaena density explains 92% of the maiming variance ($p < 0.002$; Berger & Cunningham, 1994c). While cause and effect cannot be distinguished, such relationships should lead to the supposition that hyaenas may affect calves when mothers are horned and therefore, that when mothers are dehorned, predation-related effects may result. However, it is still not known what proportion of calves are lost to predators. In Etosha for example, over the three-year period during which our study was conducted, one of 10 newborn calves died before reaching six months of age. These data, while not suitable as a control for our horned desert population, offer a glimpse of the natural mortality in a horned population with potential predators.

EVALUATION OF CONFOUNDING VARIABLES

Lindeque and Erb (1995) raise issues ranging from statistics and data interpretation to ecology and researcher disturbance. After addressing each point, we summarise our findings with respect to dehorning in the Namib Desert.

Ecological differences among areas

Lindeque and Erb (1995) argue that our study regions, namely DC (hyaena-free), SR (dehorned mothers with spotted hyaenas), and north of the veterinary fence (NVF; spotted hyaenas and occasional lions with horned mothers), differ, and therefore our contrasts are ill-conceived. However, if the areas differ strongly, then estimates of herbivore biomass also should differ. We evaluated ecological variation among study areas by contrasts of large herbivore biomass, data gathered during 126 driving transects that varied in mean length from 15.1 to 67.4 km and covered a total of 5,106 km (Table 1). Crude (as opposed to ecological) density (Eisenberg & Seidensticker, 1976) was the number seen per km² with sightings recorded to within one

kilometre on each side of a vehicle. Because data were not normally distributed (means and variance were correlated), data were log transformed with $Y = \log(x + 1)$ to avoid the problem of having zeros in which the log is negative infinity (Zar, 1984).

Using the biomass data presented in Table 1, neither study region nor year produced significant influences ($F_{2,72} = 0.09$; $F_{2,72} = 1.40$); only season did ($F_{1,72} = 9.74$ $p < 0.01$). These data suggest similarities among areas, not the striking differences alleged by Lindeque and Erb (1995). Furthermore, in an attempt to show that the SR was overgrazed, Lindeque and Erb reported "some 500 small stock (goats and sheep) and cattle were moved into the SR rhino concentration area". They cited Loutit and Montgomery (1994b) who had misinterpreted Morkel's (1992) report of a rhino mortality in the DC region when 408 head of cattle and 85 goats had been counted. Thus, the site where a young rhino apparently starved to death was not the actual site that Lindeque and Erb (1995) claimed to be the one where domestic stock had overgrazed the area.

In sum, our measures of rhino body condition and changes in patterns of herbivore biomass across three contiguously distributed study areas lead us to believe that the regions were ecologically similar. Lindeque and Erb (1995) should demonstrate that the geographic variation they purport is responsible for differences in rhino performances.

Prudence and statistics in conservation biology

Lindeque and Erb (1995) point out that Martin (in press) used the same statistical procedures as we, but reached a different conclusion. Unable to address this issue without seeing the Martin paper (which had no record of being accepted for publication in *Conservation Biology* [E. Main, managing editor, pers. comm.]), it is worthwhile examining why we reported differences in calf survivorship among our three study regions.

We previously used the Fisher's Exact Test (FET) which, in analyses of these sorts, has been criticised because it requires that both marginal totals be fixed (Berger & Kock, 1989). However, the number of possible calf deaths is not fixed. A more appropriate analytical technique is the conditional binomial exact test (CBET; Rice, 1988), more powerful and appropriate for small samples (Jenkins, 1995). Although our prior analyses using the FET revealed

statistical differences ($p < 0.05$), with the CRET differences are even more substantive (DC vs SR, $p = 0.0117$; DC vs NVF, $p = 0.0062$; both one-tailed). Thus, given the existing data, we must initially reject the hypothesis that dehorning does not decrease calf survival.

Additional data must, of course, be gathered to address the issue more fully and, as we have pointed out elsewhere (Berger & Cunningham, 1994a,b), the results were collected under a specified set of conditions in the Namib Desert. Calf mortalities could have been exacerbated by the migration of herbivores promoted by low rainfall. Rhinos did not migrate and predator-prey ratios changed (Cunningham & Berger, in press). Where spotted hyaenas utilise both migratory and sedentary herbivores, predation is more intense on local prey during the dry season (Cooper, 1990). There is no reason to expect that hyaenas were incapable of killing the calves of mothers who had been dehorned, particularly because prey switching in carnivores is common (Hamlin *et al.*, 1984; Karanth & Sunquist, 1995).

Despite our finding of differences in calf survival among sites, there is a broader issue. Had the differences not been significant at the $p < 0.05$ level, should we have been complacent to accept the null hypothesis (Toft & Shea, 1983), in this case that dehorning does not decrease calf survival? The risk of wrongly accepting the null hypothesis (a Type II error) appears much greater than that of accepting the alternative - that dehorning affects calf survival. If we are wrong and dehorning does not affect calf survival, calves will still be recruited into populations. Given that sample sizes are small and, therefore, the power to detect differences low, we believe that any acceptance of the null is imprudent. Erring on the side of conservative strategies would seem to be in the better interest of rhinos, at least until greater statistical power can be gained.

Data interpretation and experimental design

While Lindeque and Erb (1995) have taken issue with our comparative analyses, they did not report calf survival of known females pre-and post horn removal. Prior to dehorning, at least two and more likely three SR cows gave birth to calves that survived until at least one year of age. After dehorning none survived (Berger & Cunningham, 1994b). Using the CBET, the differences are significant, even with the more

conservative sample of only two births ($p = 0.026$). Thus, irrespective of whether we either contrast areas or use pre- vs post-dehorning comparisons, the evidence supports our contention that calf survival of dehorned mothers was lower in areas with spotted hyaenas.

Researcher disturbance and hidden calves

Lindeque and Erb (1995) questioned whether our presence affected the period of separation between mothers and young. Because young calves often do not accompany their mothers to water, they may be preyed upon during their mother's absence. Is it possible that our presence caused calf abandonment? Yes, but we think not and offer three arguments why. First, after spending two weeks with a Ministry and SRT dehorning team in 1991 that made use of six to 15 trackers, four to eight vehicles, and a helicopter, there was massive disturbance to rhinos in the DC area. Calf abandonment did not occur but calves were more than six months of age.

Second, we adopted methods used by both Ministry biologists and SRT trackers for finding and photographing rhinos. These included following tracks, moving to within 70m of animals to photograph horns so that size could later be estimated (Berger *et al.*, 1993), and more distant observations with spotting scopes. In five cases, we discovered mothers had been separated from young calves by finding spoor near water and following it back to sites where the two animals re-united. To our knowledge, calf abandonment has not occurred although the relationship between humans and mother-young periods of separation has not been studied systematically. Third, in no case where animals fled from us did we discover that mothers and calves separated. Thus, the only study region from which calves disappeared was that where dehorned mothers were sympatric with spotted hyaenas.

THE PUBLIC INTEREST

While the public, NGOs and many governments remain committed to the protection of rhinos, viewpoints differ with respect to the most appropriate methods. Clearly, rhinos will not survive *in situ* without substantial funding (Leader-Williams, 1990). Whether dehorning can be used effectively remains an open question and our results from the Namib Desert have been used and debated from different perspectives.

Table 2 summarises our major hypotheses and possible effects of different variables on calf survival. Do our data prove that the missing calves were killed by spotted hyaenas? No, but they suggest that other factors are less likely to have played the prominent roles claimed by Lindeque and Erb (1995).

It is important to explain our decision to publish our findings despite the small sample. First, numerous claims have been made in host countries about the

wisdom of dehorning. Second, despite claims of effective monitoring programmes, the fact is that calves were missing. Third, we felt that the scientific and conservation communities as well as the public had a right to know. Because inter-birth intervals of desert rhinos may average three years or longer, the time required to bolster our sample would have been several more years. We attempted to circumvent this problem by continuing to monitor and evaluate pregnancies. Meanwhile, we filed reports with the Namibian

Table 2. Summary of major hypotheses, tests and potentially confounding variables concerning calf recruitment in dehorned rhinos in the Namib Desert.

Construct	Tests and Evidence	Comment	Source
dehorning does not affect calf survival	1) between-site contrasts of horned and dehorned mothers ($p < 0.006$) 2) individual contrasts, pre-and post-dehorning ($p < 0.012$)	three sites only	1,2
sample size	subdivided among three sites	10 calves	2
hyaenas evenly distributed	between-site contrasts of spoor, calls, and observations	detected at two sites only	1
areas differ ecologically	1) sites contiguously distributed 2) contrast rhino body condition 3) contrast herbivore biomass	-differences not detected -differences not detected	2,3
maternal age	age estimation by horns	primiparity unlikely	2,4
drought	1) compare 1992-1993 with prior years 2) compare 1991 -1 992 and 1992-1993 combined with prior years	not the "worst drought in human memory in Namibia"	1
overlap of maternal horn sizes	contrast mothers with surviving and non-surviving calves in areas with and without hyaenas	$p < 0.029 (N=7)$	1
calf presence	small tracks of female lactating	97% accuracy	2
human disturbance	same methods used at all sites	calf separation has not occurred	1.

Sources: 1- this paper, 2-Berger & Cunningham (1994b), 3-Berger et al. (1994), 4-Berger(1994).

government and met with top ranking officials over the issue of missing calves and poor records.

Our study to evaluate biological consequences of horn removal had received official approval by the Namibian government. Despite a research programme that included more than 100 individually-known rhinos, horn size data on more than 95% of these, and more than 1,030 hours of observation during 197 night watches, because of our results our research permits were not renewed.

Still, the real issue is not whether our study should have been continued but what is in the best interests of rhinos (Cunningham & Berger, in press). In the long term, the Namibian government will have to decide whether it is better to operate in a data-less vacuum than to sanction research when it is unclear whether the *a priori* outcome will support policy. This is precisely why conflicts of interest must be avoided, so that scientifically-based research is truly independent.

ACKNOWLEDGEMENTS

For providing access to unpublished data and weather records we thank numerous co-operators: Pierre Du Preez, Peter Erb, Bill Gasaway, Duncan Gilchrist, Eugene Joubert, Pauline Lindeque, Rupert Lofte, Garth Owen-Smith, SRT, and the Namibian Ministry of Environment and Tourism. We greatly appreciate the thoughts, comments, and criticisms of Phoebe Barnard, Janet Rachlow, Peter Stacey, Rob Simmons, an anonymous reviewer and Ruth Chungue. We did not always follow their suggestions and they do not necessarily endorse our views.

REFERENCES

- Bamard, P. (1991) Ornament and body size variation and their measurement in natural populations. *Biol. J. Linn. Soc.* 42,379-388.
- Berger, J. & Kock, M. (1989) Type I and Type II errors in the real world. *J. Wildl. Dis.* 25,451-454.
- Berger, J., Cunningham, C. & Gawuseb, A.A. (1994) The uncertainty of data and dehorning black rhinos. *Cons. Biol.* 8,1149-1152.
- Berger, J. (1994) Science, conservation, and black rhinos. *J. Mamm.* 75,298-308.
- Berger, J., Cunningham, C., Gawuseb, A. & Lindeque, M. (1993) Costs and short-term survivorship of hornless black rhinos. *Cons. Biol.* 7,920-924.

Berger, J. & Cunningham, C. (1994a) Active intervention and conservation. *Science* 263,1241-1242.

Berger, J. & Cunningham, C. (1994b) Phenotypic alterations, evolutionary significant structures, and rhino conservation. *Cons. Biol.* 8,833-840.

Berger, J. & Cunningham, C. (1994c) Horns, hyaenas, and rhinos. *Research and Exploration* 10,241-244.

Berger, J. & Cunningham, C. (1995) Predation, sensitivity, and sex: why female black rhinoceroses outlive males. *Beh. Ecol.* 6,57-64.

Cameron, R.D. & Ver Hoef, J.F. (1994) Predicting parturition rate of caribou from autumn body mass. *J. Wildl. Manage.* 58,674-679.

Cooper, S.M. (1990) The hunting behaviour of spotted hyaenas (*Crocuta crocuta*) in a region containing both sedentary and migratory populations of herbivores. *Afr. J. Ecol.* 28,131-141.

Cunningham, C. & Berger, J. (In press) *Horn of Darkness: Rhinos and Conservation Chimeras in Africa*. Oxford University Press.

Eisenberg, J.F. & Seidensticker, J. (1976) Ungulates in southern Asia; a consideration of biomass estimates for selected habitats. *Biol. Cons.* 10,293-308.

Hamlin, K.L., Riley, S.J., Pyrah, D., Dodd, A.R., & Mackie, R.J. (1984) Relationships among mule deer fawn mortality, coyotes, and alternate prey species during summer. *J. Wildl. Manage.* 48,489-499.

Jenkins, S.H. (1995) Carfentanil, bison, and statistics: the last word? *J. Wildl. Dis.* 31,104-105.

Joubert, E. & Eloff, F.C. (1971) Notes on the ecology and behaviour of the black rhinoceros *Diceros bicornis* Linn 1758 in South West Africa. *Mado qua*, 1,5-53.

Karanth, R.U. & Sunquist, M.E. (1995) Prey selection by tiger, leopard, and dhole in tropical forests. *J. Anim. Ecol.* 64,439-450.

Keep, M.E. (1971) Observable criteria for assessing the physical condition of the white rhinoceros *Ceratotherium simum simum*. *Lammergeyer* 13,25-28.

Laurenson, M.K. (1994) High juvenile mortality in cheetahs (*Acinonyx jubatus*) and its consequences for maternal care. *J. Zoo! Land.* 234,387-408.

-
- Leader-Williams, N. (1990) Black rhinos and African elephants: lessons for conservation funding. *Oryx* 24,23-29.
- Leader-Williams, N. (1993) Theory and pragmatism in the conservation of rhinos. In: *Rhinoceros Biology and Conservation* (ed. O. A. Ryder). San Diego Zoological Society, San Diego, Ca.
- Liebenberg, L. (1990) *A Field Guide to Animal Tracks of Southern Africa*. David Phillip Publishers, Cape Town.
- Lindeque, M. (1990) The case for dehorning the black rhinoceros in Namibia. *S. Afr. J. Sci.* 86,226-227.
- Lindeque, M. & Erb, P. (1995) Research on the effects of temporary horn removal on black rhinos in Namibia. *Pachyderm* 20,27-30.
- Loutit, B.L. & Montgomery, S. (1994a) Rhino conservation. *Science* 265, 1157-1158.
- Loutit, B.L. & Montgomery, S. (1994b) The efficacy of rhino dehorning: too early to tell! *Cons. Biol.* 8,923-924.
- Mills, M.G.L., Nel, J.A.J. & Bothma, J. Du P. (1984) Notes on some smaller carnivores from the Kalahari Gemsbok National Park. Supplement to *Koedoe* (1984), 221-227.
- Morkel, P.V. (1992) Report on the death of a black rhino (*Diceros bicornis bicornis*) in the Ugab River. Save the Rhino Trust, Windhoek, Namibia. Unpublished report.
- Rice, W.R. (1988) A new probability model for determining exact P - values for 2 x 2 contingency tables when comparing binomial proportions. *Biometrics* 44,1-22.
- Skinner, J.D. & Van Aarde, R.J. (1981) The distribution and ecology of the brown hyaena *Hyaena brunnea* and spotted hyaena *Crocuta crocuta* in the central Namib Desert. *Mado qua* 12,231-239.
- Skinner, J.D. & Smithers, R.H.N. (1990) *The Mammals of the Southern African Subregion*. University of Pretoria, South Africa.
- Toft, C.A. & Shea, P.J. (1983) Detecting community-wide patterns: estimating power strengthens statistical inference. *Am. Nat.* 122,618-625.
- Western, D. (1982) To dehorn or not to dehorn. *Swara* 5,22-23.
- Western, D. (1987) Africa's elephants and rhinos: flagships in crisis. *Tree* 2,343-346.
- Zar, J.H. (1984) *Biostatistical Analyses*. Prentice Hall, Engelwood Cliffs, New Jersey.

A NATIONWIDE SURVEY OF CROP-RAIDING BY ELEPHANTS AND OTHER SPECIES IN GABON

Sally A. Lahm

Institut de Recherche en Ecologie Tropicale, BP 180, Makokou, Gabon

INTRODUCTION

Gabon harbours one of the largest elephant populations in Africa. Barnes *et al.* (1993) estimated that there are about 61,000 elephants in the country. The distribution of elephants in Gabon is greatly influenced by past and present human activities such as settlement patterns, hunting and logging (Barnes, 1991; Lahm, 1993, 1994). While villagers were formerly semi-nomadic, they now live in permanent communities along roads and major waterways, leaving extensive areas of uninhabited terrain and secondary regrowth in the forest interior.

As in other African countries (Bell, 1984; Osborn, 1992; Hoare & Mackie, 1993; Tchamba, 1995), elephant crop-raiding is a major problem in Gabon. Requests for government action to control elephant crop destruction have increased greatly within the past ten years despite the fact that villagers have dealt with crop-raiding animals for centuries.

To address this issue, a nationwide survey of village families was conducted from July 1993 to June 1994, under the direction of the African Elephant Conservation Co-ordinating Group (AECCG) in cooperation with the World Wide Fund for Nature, Gabon and the Ministry of Water and Forests. The primary objectives were to determine the extent and severity of crop-raiding by elephants and other animals and to assess the factors involved as a means to finding solutions. This paper presents the results of the survey.

METHODS

Survey team members included the author, two agents of the Ministry of Water and Forests and a villager who served as project assistant. Data were collected by means of a questionnaire pertaining to sources of income, agricultural practices, problems with crop destruction by animals and traditional methods of deterrence.

Villages were selected by stratified random sampling on road sections and populated waterways in each of the nine provinces of Gabon. Analysis of data from an initial pilot study of 38 villages in one province showed the optimum sample size for all other provinces to be between 15 and 20 villages. Ten to 30 families were interviewed in each village, depending on the size of the community and the availability of residents. In total, 2,926 families were interviewed in 218 villages throughout the country.

Families were asked to place crop-raiding animals into two categories: 1) most destructive (severe); 2) less destructive (minor). Where crop damage by elephants or other large mammals (buffalo, gorilla, bush pigs) was reported on a family's plantation(s), an investigator briefly assessed the damage using specific guidelines. These included notation of the crop(s) damaged, age of plantation, date and season of raiding, animal species responsible, distance of plantation from the village and proportion of crop(s) damaged.

STUDY AREA

Socio-economy

Gabon has a relatively small human population compared to many other African countries - about one million people - and an average density of 3.8 persons/km². About 60% of the people live in urban areas (data from Ministry of Planning, 1993). The major sources of revenue are oil, manganese, uranium and timber. Since the decrease in the price of oil in 1985 and the devaluation of the CFA franc in 1994, urban unemployment, commercial logging, and the economic dependency of villagers on the sale of crops and bush meat have increased dramatically (Tutin, 1992; Lahm, 1993).

Flora and fauna

The forests of Gabon are part of the Guineo-Congolian phytogeographic region which stretches from Guinea to eastern Zaire (White, 1983). About 15% of the country

is comprised of swamp, mangroves, steppe and savanna. At least 75% to 80% is forested (Caballe, 1983).

More than 130 species of mammals have been identified throughout Gabon, including 19 species of primates, 16 species of artiodactyls and at least 30 species of bats (Emmons *et al.*, 1983).

Regional agricultural practices

The small-scale, subsistence-orientated farming strategies are adapted for the local climate and topography. The major crops are bitter and sweet manioc, bananas, peanuts, maize and taro. Farmers practise rotational shifting cultivation. Crops are harvested for a few years from the same plantation, which is then left fallow for several more years.

In savanna areas of south-eastern, south-western and coastal Gabon, where the climate is characterised by one long, pronounced dry season, crops are planted once per year. Fields are cleared and planted twice per year in continuously forested areas elsewhere in the country (with equatorial and transitional climates), where there are two shorter, less well-defined, dry seasons.

Plantations are located as close to villages as possible, but the agricultural system demands much terrain. The distance of the crops from the villages depends on the local habitat and population size and may range from a few hundred metres to several kilometres or more. Most Gabonese farmers cultivate on the edge of the forest. Family members often plant in “blocks” of three or four contiguous fields, but the crops of an entire community are scattered over a wide area around the village. This, plus the fact that food is continuously harvested, increases the risk of year-long animal depredations.

Problem animal control policy

Elephant hunting was banned in Gabon in 1981. In cases of excessive crop destruction, the government may authorise control shooting, namely “battue administrative”. The complainant contacts the local provincial office of the Ministry of Water and Forests. After inspection of the damage, a report is submitted to the provincial governor who should decide within eight days whether to authorise control shooting. Once given, the authorisation is valid for one month during which a maximum of two elephants, preferably males, may be shot by a designated hunter within five kilometres of

the village. The tusks remain government property and the meat is given to the hunter and villagers. In reality, the decision may be delayed for weeks or months and/or authorised control shootings are seldom implemented because hunters are not paid and high-powered firearms cannot be found. Villagers usually bear the loss or resort to their own methods.

RESULTS

Village economy

Crops destroyed by animals represent a loss of food as well as income for villagers. Between 53% and 85% of the 2,926 families considered the sale of agricultural products to be a major source of income, depending on access to clients and local markets, especially large coastal cities. Most villagers sell some surplus crops. The sale of cane, palm and maize wines are important sources of revenue in three provinces in the interior of the country.

Crop-raiding species

Villagers named a total of 34 species of crop-raiding animals which included reptiles, birds and mammals, as listed in Table 1. Three species were mentioned frequently as the most destructive and/or persistently present in plantations. In descending order of importance these were: the cane rat, the elephant and the brush-tailed porcupine.

Of the ten species of primates cited, only the mandrill, the talapoin and the white-collared mangabey each had greater than 1% representation of the total number of complaints. The forest buffalo and the bush pig were the only ungulate species among the nine cited which inflicted measurable crop damage.

Apart from unidentifiable mice and rats, villagers named seven species of rodents as crop-raiders. These ranged in size from the 100-150g striped squirrels to the 3-5kg cane rat. Even where villagers had no problems with elephants, the cane rat was always present, along with a variety of other animals which together form a “guild” of crop-raiders capable of inflicting destruction on a large proportion of crops.

With the exception of one province, the cane rat had the highest median percentage of total complaints about severe crop-raiding throughout Gabon, surpassing the elephant, as seen in Table 2.

Table 1. List of crop-raiding species cited by villagers in Gabon.

Common name	Scientific name
Reptiles	
Black burrowing snake	<i>species unknown</i>
Nile monitor lizard	<i>Varanus niloticus</i>
Birds	
Francolin	<i>Fracolinus squamatus</i>
Green fruit pigeon	<i>Treron australis</i>
Weaver	<i>Ploceus cucullatus</i>
Mammals	
Rodents	
Brush-tailed porcupine	<i>Atherurus africanus</i>
Cane rat	<i>Trynomys swinderianus</i>
Emin's rat	<i>Cricetomys emini</i>
Four-striped squirrels	<i>Funisciurus isabella, F lemnicatus</i>
Palm squirrel	<i>Epixerus ebii</i>
Stanger's squirrel	<i>Protoxerus stangeri</i>
Pangolins	
White-bellied pangolin	<i>Manis tricuspis</i>
Primates	
Black colobus	<i>Colobus satanas</i>
Gray-cheeked mangabey	<i>Cercocebus albigena</i>
White-collared mangabey	<i>Cercocebus torquatus</i>
Mandrill	<i>Mandrillus sprinx</i>
Moustached guenon	<i>Cercopithecus cephus</i>
Sun-tailed guenon	<i>Cercopithecus solatus</i>
Greater white-nosed guenon	<i>Cercopithecus nictitans</i>
Talapoin	<i>Miopithecus talapoin</i>
Chimpanzee	<i>Pan t. troglodytes</i>
Gorilla	<i>Gorilla g. gorilla</i>
Artiodactyls	
Bates's pygmy antelope	<i>Neotragus batesi</i>
Bay duiker	<i>Cephalophus dorsalis</i>
Blue duiker	<i>Cephalophus monticola</i>
Yellow-backed duiker	<i>Cephalophus sylvicultor</i>
Bushbuck	<i>Tragelaphus scriptus</i>
Sitatunga	<i>Tragelaphus spekei</i>
Chevrotain	<i>Hyemoschus aquaticus</i>
Forest buffalo	<i>Syncerus caffernanus</i>
Bush pig	<i>Potamochoerus porcus</i>
Hippopotamus	<i>Hippopotamus amphibius</i>
Proboscideans	
Forest elephant	<i>loxodonta africana cyclotis</i>

Table 2 Medians of percentages of total complaints for the cane rat and the elephant in the nine provinces of Gabon.

Province	Cane rat		Elephant	
	%	Range	%	Range
Estuaire	78	49-89	11	0-27
Haut-Ogooue	58	37-72	6	0-13
Moyen-Ogooue	28	9-70	25	6-59
Ngounie	59	17-95	12	0-83
Nyanga	37	11-78	17	0-64
Ogooue-Ivindo	54	21-69	28	4-45
Ogooue-Lolo	68	43-79	15	0-45
Ogooue-Maritime	17	0-36	59	14-65
Woleu-Ntem	86	43-100	13	0-50

Distribution of severe elephant destruction

Elephant crop-raiding occurred in all provinces. However, the cane rat accounted for more than 50% of total complaints about severe destruction of crops in six of the nine provinces (Table 2). This is because elephant crop-raiding varied greatly among and within provinces and appears to be both a seasonal and localised problem.

When registering complaints, villagers were asked to differentiate between severe and minor elephant damage. Severe damage was defined as frequent raids by elephants and/or a large proportion of crops destroyed during raids. Minor damage meant insignificant loss of crops. The map shows the three provinces, Ogooue-Maritime, Moyen-Ogooue and Ogooue-Ivindo, from which complaints about severe elephant crop destruction were most frequent. Those provinces with the least complaints were Estuaire and Woleu-Ntem in the northwest and Haut-Ogooue in the southeast, while the remaining provinces had scattered complaints about elephants on some road sections and none on others.

Crops eaten by elephants

Elephants eat a wide variety of crops including bananas, manioc, yams, sweet potatoes, pineapples and occasionally sugar cane. They appear to select banana plants of intermediate growth stage, breaking the stems to eat the inner core and young leaves. Of 79 crop-raiding evaluations in which maize stalks were

destroyed by elephants, the majority (71%) of cases involved stalks which were trampled rather than eaten.

Elephants also seem to uproot and trample more bitter manioc than they actually eat, but they consumed most tubers of uprooted sweet manioc plants. They chewed sugar cane stalks and spat out the pulp.

Analysis of crop damage

We investigated a total of 132 cases of animal crop-raiding. Of these, 106 (80%) involved elephants only, 11% were attributed to elephants combined with other species such as pigs and gorillas, 4% were due to cane rats and 2% involved mandrills. The gorilla, bush pig and buffalo each had 1% representation of assessed crop-raiding incidents.

From evaluations of crop damage and conversations with villagers, it appears that bananas are the primary attraction for elephants. Bananas are usually planted on the plantation/forest edge where humus is present. This makes them more susceptible because elephants can easily feed and quickly return to the forest cover. Bananas were the most heavily damaged crop in the majority of investigated cases. We recorded damaged banana stems in 125 of 132 crop damage assessments, as shown in Table 3. From 81% to 100% of banana plants were destroyed in 54% of these incidents compared to 30% and 29% of cases of destruction of manioc plants and other crops, respectively, in the same percentage category level.

The extent of crop destruction varied. There were narrow trails of trampled crops where elephants passed through plantations into forest, providing evidence for limited foraging along the plantation/forest edge. There was also extensive feeding, uprooting and trampling by small groups of two to four animals. Elephants appeared to target banana stems first, then searched for other foods in an exploratory manner.

It was not always possible to estimate the number of animals involved. One elephant was implicated in 36 (63%) of 57 incidents and two or three elephants raided in 17(30%) of these cases. Most crop-raiding elephants remained within one or two "blocks" of plantations. In one well documented case, elephants foraged three times in the same three-hectare block of adjacent plantations within seven months, but did not move into other planted areas elsewhere near the village.

Figure. Provincial map of Gabon showing the three provinces most affected by elephant crop-raiding. Table 3. Percentage damage to plant foods from a total of 132 elephant crop-raiding incidents.

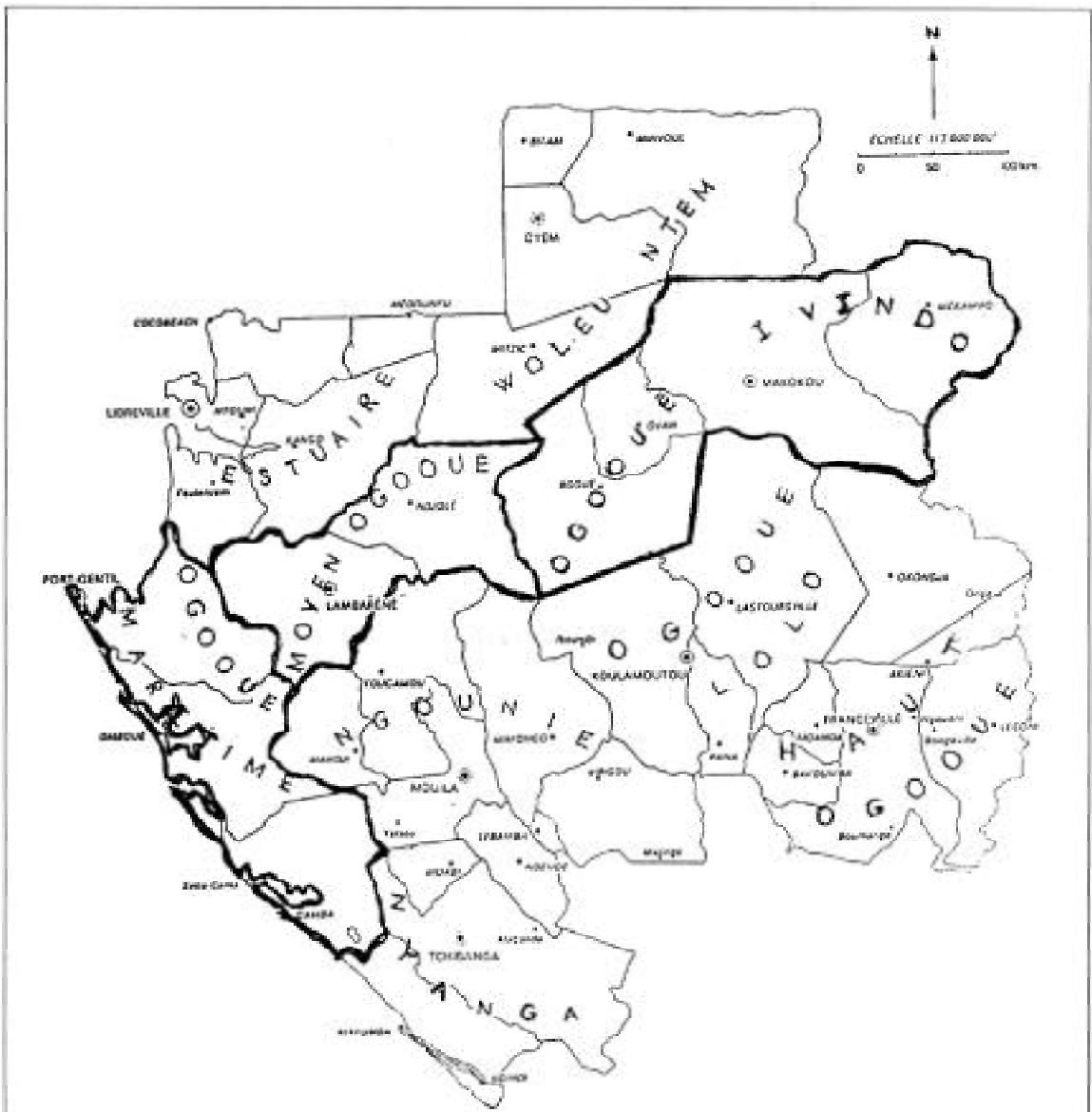

Figure. Provincial map of Gabon showing the three provinces most affected by elephant crop-raiding.

Table 3. Percentage damage to plant foods from a total of 132 elephant crop-raiding incidents.

crop	No. Cases	Percentage damage									
		0-20		21-40		41-60		61-80		81-100	
		No.	(%)	No.	(%)	No.	(%)	No.	(%)	No.	(%)
Manioc	122	18	(15)	38	(31)	18	(15)	11	(09)	37	(30)
Bananas	125	19	(15)	07	(06)	19	(15)	12	(10)	68	(54)
Other*	123	26	(21)	05	(05)	03	(02)	53	(43)	36	(29)

*taro, maize, sweet potatoes, yams, concombre gourds, pineapples, sugar cane

Seasonality of crop-raiding

Elephant presence in plantations in Gabon appears to be influenced by seasonal change. Villagers in forested regions said that most elephants migrate towards swamps and rivers during the long, dry season (July, August) and disperse into the forest towards villages when the rains begin again in September/October. Of 229 registered incidents of elephant crop-raiding near forest villages, the majority occurred during a wet season (Table 4). Few people said that elephant damage did not occur during a defined season. It appears that elephants generally do not feed in plantations during January and February, which is the short, dry season, when fruits and herbs are abundant in the forest. Thus, there are fewer cases of elephant crop-raiding in forest villages during dry conditions.

The phenomenon is less clear for savanna areas owing to regional variations. In south-eastern and southwestern Gabon, most registered crop-raiding incidents in savanna villages occurred during the long, dry season (Table 4). However, on coastal savannas, which are largely in a transitional climatic zone between equatorial and pure tropical climates, people said that elephant depredations occur mainly during the wet season.

Table 4. Number of registered elephant crop-raiding incidents in relation to habitat type and season.

Habitat type	No. of cases	S E A S O N S				All year	
		Dry No.	(%)	Wet No.	(%)	No.	(%)
Savanna	85	59	(69)	23	(27)	03	(04)
Forest	229	55	(24)	174	(71)	11	(05)

Traditional deterrence measures

Survey results indicate that many villagers make little effort to protect their plantations. Of the 2,926 families interviewed, 1,053 (36%) said that they do nothing to deter crop-raiding. Thirty-eight percent said that they set traps around plantations; 23% erect barriers of palm fronds, wooden slats or old, tin roofing material; and 11% camp near their crops. Four percent of respondents hunt near their plantations. Most of the traps observed were set for animals ranging in size from large rodents to duikers. We saw only two traps made for elephants.

Methods used specifically to deter elephants included lighting fires or lamps at plantation perimeters (5% of 2,926 families), beating on metallic surfaces (4%), hanging cables or vines with attached bottles and tin cans (3%), and making scarecrows (3%). In some cases of persistent elephant crop-raiding, people eventually abandoned the location in recognition of the elephants' attraction to a local resource nearby, such as a swamp or fruiting trees.

DISCUSSION

Government policy

The largely ineffective use of control shooting to curtail elephant crop-raiding in Africa has served mainly to appease villagers (Bell, 1984; Hoare & Mackie, 1993). Compensation schemes have had little success in Kenya and Cameroon (Ngure, 1995; Tchamba, 1995).

Theoretically, control shooting of elephants could reduce crop-raiding by conditioning group members when more than one elephant is involved. However, the centralised decision-making process is burdensome and usually is delayed for weeks or months during which the raiding elephant(s) may have left the vicinity (Lahm, 1994; Kangwana, 1995).

In Gabon, control shooting usually occurs long after the event. Because the law requires that an elephant be shot within five kilometres of the affected village, delayed authorisations may result in the death of a non-raiding animal while the original culprit(s) may return. More often, no control shooting occurs because neither the hunter nor the appropriate firearm are available. Despite this, all families interviewed in the survey who were affected by elephant crop-raiding preferred shooting elephants to compensation because they feared continuation of raids.

Obviously, a change in policy is needed not only to ameliorate the problem but to improve the strained relations between the villagers and the wildlife agents. One suggestion is to create associations of village hunters. The hunters would be paid for control shooting and would develop a reporting system within each district, similar to that used in Zimbabwe (Hoare, 1995). This would require central government policy shifts towards local management and would be open to abusive practices, but it would ensure rapid response to severe crop damage as well as greatly improving public relations and incorporating villagers in local wildlife management.

Policies about crop-raiding elephants should be part of a national management plan for Gabon's abundant and significant elephant population. Although the elephant is an officially protected animal, and there are laws which regulate hunting and ownership of firearms, no management plan exists for the elephant or for any other species of animal in the country.

Inter- and intra-provincial differences

There was much variation in elephant damage within and among provinces, indicating that elephant crop-raiding problems might best be dealt with on provincial and local levels rather than as part of a generalised national plan. The latter would shift the decision-making process to ministry headquarters in the capital, thus increasing delays. National or provincial meetings could be held to identify and discuss local areas of persistent elephant crop-raiding. For example, in the southwest, large areas of mature, forested elephant habitat, are cleared annually for commercial banana plantations, creating a prime attraction for elephants. This can only lead to continued conflict.

The attraction of elephants to particular habitats may also influence the frequency and occurrence of crop-raiding. The three most affected provinces are characterised by large expanses of water and swampy terrain. While Barnes (1991) demonstrated that elephants show preference for secondary regrowth, Lahm (1993) and Ekobo (1995) found strong associations between elephants and "wet" habitats (swamp, marsh and seasonally inundated forest).

The rural exodus of villagers also contributes to crop-raiding. As people increasingly move to urban areas, there are fewer farmers and hunters on the land, which can then be re-occupied by elephants and other animals. In the coastal province of Ogooue-Maritime, which registered the highest number of complaints about severe elephant crop-raiding in the survey, rural exodus appeared to be accelerating. This is undoubtedly due to the proximity of Port Gentil and Libreville, the largest urban centres, and to the base of Shell Oil. Many villages in this province consisted of tiny hamlets of four or five families, often comprised mainly of older people.

Protection of plantations

Rural exodus also leads to lack of crop protection, which is considered to be work for men. Many young men go from their villages in search of work, leaving women, children and the elderly behind. Women, even

at an advanced age, continue to plant and harvest crops, but older men are frequently unable or unwilling to protect fields by setting traps, erecting barriers, etc.

Changes in village organisation and institutions have resulted in less cohesive, fragmented societies. Traditional communal practices which united village residents, such as net hunting, planting and cooperative crop protection have been largely abandoned in favour of individually-owned firearms and scattered agricultural plots (Lahm, 1993). Many young village men and boys encountered during the survey expressed disinterest in agriculture, the forest milieu or traditional male activities.

Because elephant crop-raiding is widespread and the agricultural system is no longer strategically organised for defense against crop-raiding animals, plantations cannot be protected efficiently. It is clear that electric fencing is not a viable solution to the problem of elephant crop-raiding for the majority of the rural Gabonese population. Using the criteria from Hoare (1995) for electric fencing schemes employed in Zimbabwe, it would cost at least \$21,000 to provide sufficient protection of crops for one small village of 125 people whose crops are dispersed over an area of 21km² (Lahm, 1994).

Changes in land-use planning

Unlike in Kenya, where 119 people were killed by elephants between 1990-1993 (Kiiru, 1995), elephant attacks on humans are rare in Gabon. The low human population density, clumped distribution of settlements along roads, and general lack of active defense of plantations leave fewer opportunities for elephant] human contact but more opportunities for elephant crop-raiding. Because plantations are widely dispersed, often unprotected, frequently far from villages and located on forest edges, they are highly vulnerable to crop-raiding by a variety of animals.

In conjunction with the revision of the elephant control shooting policy, current agricultural strategies could be improved with the objectives of decreasing crop-raiding, involving the participation of village men, and improving local working conditions.

Lack of time prevented evaluation of success rates of various indigenous methods of controlling crop-raiding elephants and other animals. This evaluation could be incorporated into experiments with collective planting, different fallow schemes and organised crop protection in selected villages.

Crop-raiding by cane rats

The number of overall complaints about cane rats far surpassed those of any other animal species, including the elephant. Is the latter the most economically important crop-raider? By reason of its large body size, an elephant is capable of inflicting heavy damage. However, the fact that elephant crop-raiding appears to be more of a localised and seasonal problem suggests that continuous, low-level consumption of food crops throughout Gabon by a huge, uncontrolled cane rat population may be more destructive in the long term. Therefore, the problem of crop-raiding by both species needs to be addressed further.

CONCLUSIONS AND RECOMMENDATIONS

The phenomenon of crop-raiding in Gabon is very complex and the study generated more questions than it answered. Recommendations include the improvement of farming practices, a thorough review of the elephant control shooting policy and the creation of an elephant management plan. The legalisation of elephant hunting for citizens is not proposed as a solution to the problem because elephant hunting is already widespread and largely uncontrolled in the country (Lahm, 1993, 1994; Dublin *et al.*, 1995).

Other recommendations include the improvement of the professional capacity and management capability within the Ministry of Water and Forests by training agents in the classroom and on-site, in communication skills and general public relations and providing them with standardised forms for evaluating crop damage and cases of control shooting. Finally, it is recommended that a project be developed which focusses on the control of cane rat populations.

ACKNOWLEDGEMENTS

This project was part of the European Commission (EC) African Elephant Programme (AEEP) for 1992-94. It was funded by the Ecology in Developing Countries Programme of the EC and was managed through the AECCG Secretariat at The Environment and Development Group, Oxford, UK. I wish to thank Monique Nsafou Loembe, Michel Ondo Engoang and Jean Benga Zobo for their invaluable help in data collection. My thanks to the Ministry of Water and Forests for permission to do the survey. Finally, my thanks go to Jean Wickings for providing comments on the manuscript.

REFERENCES

- Barnes, R.F.W (1991) Man determines the distribution of elephants in the rain forests of north-eastern Gabon. *Afr. J. Ecol.* 29,54-63.
- Barnes, R.F.W., Blom, A., Alers, M.P.T. & Barnes, K.L. (1993) Révision des calculs d'éléphants de forêt au Gabon. Report 'to The Wildlife Conservation Society.
- Bell, R.H.V. (1984) The man-animal interface: An assessment of crop damage and wildlife control. In: *Conservation and Wildlife Management in Africa*. (Eds. R.H.V. Bell and E. McShane-Caluzi). Office of Training and Program Support, Forestry and Natural Resources Sector, US Peace Corps.
- Caballe, G. (1983) Vegetation. In: *Geographie et Cartographie du Gabon* (Ed. J. Barret) EDICEF, Paris.
- Dublin, H.T., Milliken, T. & Barnes, R.F.W. (1995) Four Years After the C Ban: Illegal Killing of *Elephants, Ivory Trade and Stockpiles*. Report of the IUCN/SSC African Elephant Specialist Group.
- Ekobo, A. (1995) Elephants in the Lobeke Forest, Cameroon. *Pachyderm* 19,73-81.
- Emmons, L.H., Gautier-Hion, A. & Dubost, G. (1983) Community structure of the frugivorous-folivorous forest mammals of Gabon. *J. Zool. Lond.* 199,209-222.
- Hoare, R. (1995) Options for the control of elephants in conflict with people. *Pachyderm* 19,54-64.
- Hoare, R.E. & Mackie, C.S. (1993) Problem animal assessment and the use of fences to manage wildlife in the communal lands of Zimbabwe. Report to WWF and Zimbabwe's Department of National Parks and Wild Life Management.
- Kangwana, K. (1995) Human-elephant conflict: the challenge ahead. *Pachyderm* 19,11-15.
- Kiiru, W. (1995) The current status of human-elephant conflict in Kenya. *Pachyderm* 19,15-20.
- Lahm, S.A. (1993) *Ecology and Economics of Human/ Wildlife Interaction in Northeastern Gabon*. Ph.D. thesis. New York University.

Lahm, S. (1994) *The Impact of Elephants on Agriculture in Gabon*. Final report, European

Commission African Elephant Conservation Programme.

Ngure, N. (1995) People-elephant conflict management in Tsavo, Kenya. *Pachyderm* 19,20-26.

Osborn, F.V. (1992) A study of elephant/human conflict in the area surrounding the Sengwa Wildlife Research Institute, Zimbabwe. Report to Department of National Parks and Wild Life Management and the CAMPFIRE Association.

Tchamba, M.N. (1995) The problem elephants of Kaélé: a challenge for elephant conservation in northern Cameroon. *Pachyderm* 19,26-33.

Tutin, C.E.G. (1992) Gabon. In: *Conservation Atlas of Tropical Forests: Africa* (Eds. J.A. Sayer, C.S. Harcourt and N.M. Collins) Macmillan Publishers Ltd., London.

White, F (1983) *The Vegetation of Africa*. UNESCO, Paris.

Photo credit: Chris Thoulless



An elephant crossing an electric fence in Laikipia District, Kenya.

AFRICAN ELEPHANTS IN COASTAL REFUGES

Joseph P. Dudley

Hwange National Park (Main Camp), PB DT 5776, Dete, Zimbabwe

ABSTRACT

The history and status of relict elephant populations at three sites in coastal regions of Africa illustrate common elements affecting the survival of elephant populations within human-dominated landscapes. Habitat loss to agriculture and ivory hunting have been major factors driving the fragmentation, isolation and extinction of African elephant populations. Elephants survived within coastal regions in the three sites under discussion (Kakum, Ghana; Knysna, South Africa; Addo, South Africa), due to the presence of core habitat areas protected as government forest reserves. The presence of habitat refuges, not protected status for elephants *per se*, was the key factor in elephant survival at all sites. Genetic studies of small elephant populations with known histories may prove useful for the future management of genetic diversity in wild and captive populations of both species of elephants (*Loxodonta africana*, *Elephas maximus*).

INTRODUCTION

Humans and elephants have co-existed in Africa for at least the past million years, with the continent serving as their common centre of evolutionary development. The scope and scales for human-elephant interactions have altered markedly through time, first with the development of agriculture and more recently with the widespread availability of modern firearms. The earliest recorded extinctions (1,500-4,000 BC) of regional elephant populations occurred in major centres of early agricultural civilisation: North Africa, the Middle East, and the Yangtze Valley of China (Olivier, 1978; Cumming *et al.*, 1990). The ability and propensity of elephants to damage crops and the effectiveness of firearms as a tool for killing elephants have resulted in their extirpation throughout much of their range during the past century.

Human-elephant conflict

historically been major factors in eliminating African elephants from large areas of their historic range (Cumming *et al.*, 1990). Human population increases

are predicted to cause further major reductions in habitat for African elephants during the coming century (Parker & Graham, 1989). Habitat loss is currently the greatest threat to the survival of the Asian elephant (Santiapillai & Jackson, 1990), and will in all probability become the ultimate threat to survival of the African elephant (Cumming *et al.*, 1990). The long-term importance of habitat loss as a threat to the survival of the African elephant needs wider recognition (Armbruster & Lande, 1993).

Elephants are keystone herbivores whose foraging activities profoundly influence the structure, composition and productivity of vegetation communities within their habitats (Laws *et al.*, 1975; Eisenberg, 1981). This keystone ecological function of elephants often directly conflicts with the requirements of human agro-ecosystems. Agriculture, silviculture and human settlements within or adjacent to elephant habitats typically result in severe human-elephant conflicts (Pitman, 1934; Seidensticker, 1984; Eltringham, 1990; Newmark *et al.*, 1994). Competition for resources (e.g., water, grazing, trees) and physical confrontations may result in injuries and deaths among both humans and elephants (Pitman, 1934; Seidensticker, 1984). Free-ranging elephant populations are for the most part incompatible within or adjacent to areas of intensive agriculture. Habitat conversion and fragmentation caused by agriculture and deforestation greatly increase incentives and opportunities for the decimation or extermination of local elephant populations (Tchamba & Mahamat, 1992).

CASE STUDIES

The history and status of three sites in near-coastal regions of sub-Saharan Africa serve to demonstrate the interplay of ecological and cultural factors in the survival of elephant populations within areas where elephants have been largely extirpated due to habitat fragmentation and conversion. The sites under discussion are (Figure 1, Table 1):

- 1) Kakum National Park and Assin-Attandanso Wildlife Resource Reserve, Central Region, Ghana (Kakum).
- 2) Diepwalle and Gouna State Forests, Southern Cape Province, Republic of South Africa (Knysna).
- 3) Addo Elephant National Park, Eastern Cape Province, Republic of South Africa (Addo).

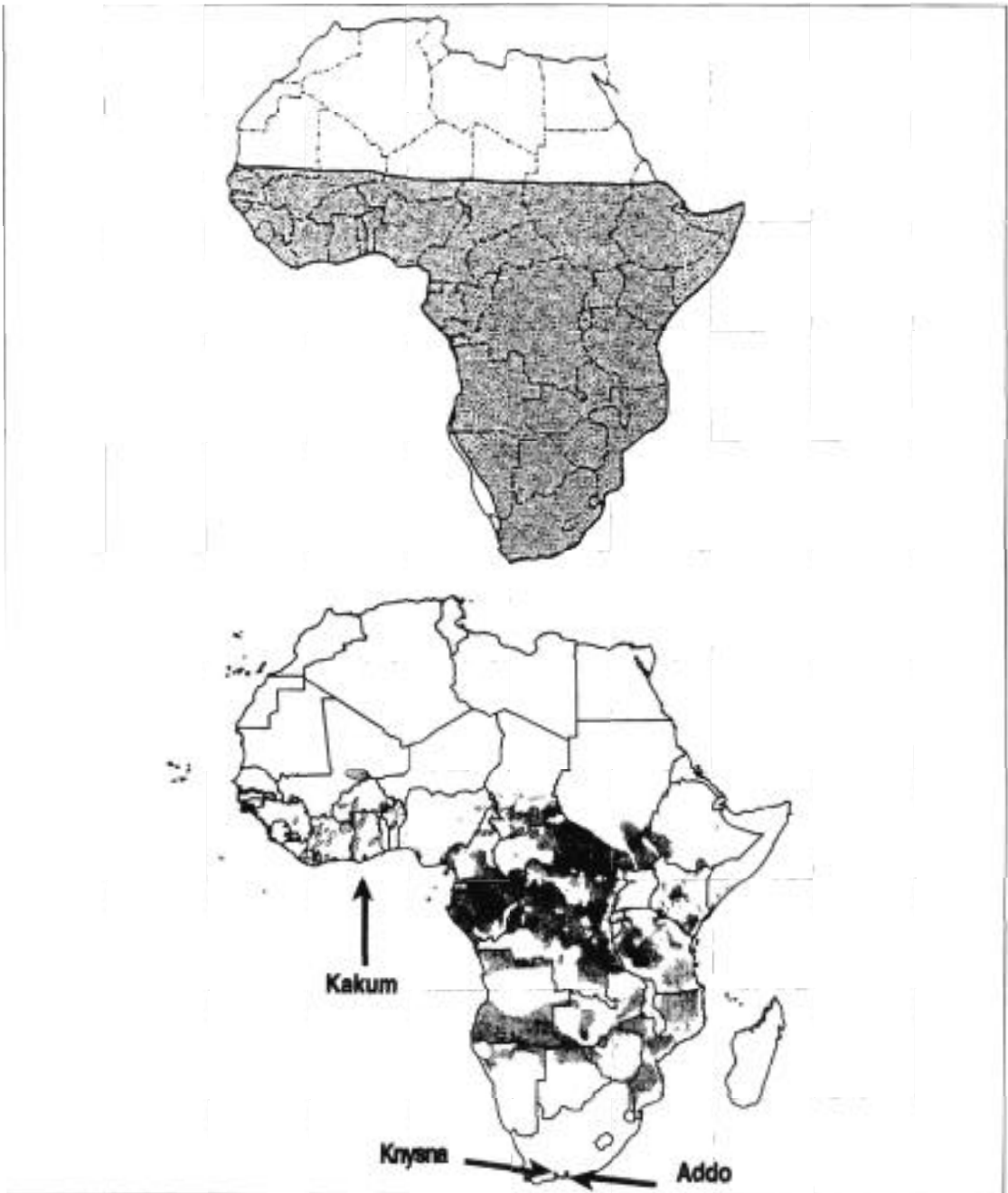

Figure 1. African elephant distributions in A) ca. 1600 (Cumming et al., 1990) and B) 1995 (Said et al., 1995) showing the three site locations.

All three sites are currently completely isolated from contact with other, elephant populations, over time spans of up to two hundred years (Table 2). All three sites were first protected under forest reserve status by British colonial administrations, with their protected area status maintained or upgraded to national park status by post-colonial national governments. All three populations were restricted to patches of dense native vegetation which survived within otherwise human-dominated landscapes under protection as forest reserve and/or national park status. Severe population bottlenecks occurred during the past century in at least two of these three sites (Addo & Knysna: Burton, 1968; Hall-Martin, 1993). None of these populations appears to have been significantly affected by ivory poaching during the past two decades (Dudley *et al.*, 1992; Hall-Martin, 1993).

The Kakum elephant population (estimated at 100-150 individuals) appears stable within a 347km² rainforest area recently converted from Forest Reserve to National Park/Game Reserve status as part of a regional tourism development and watershed

conservation project (Dudley *et al.*, 1992). The Addo elephant population, currently estimated at 212 individuals (Knight & Hall-Martin, 1995), is thriving within the fenced precincts of the long-established Addo Elephant National Park (120km²). In Knysna, there is only one survivor from the remnant population, which lives within a 150km² area of indigenous forest, fynbos scrubs, and pine/eucalyptus forestry plantations protected under State Forest status. A re-introduction programme is currently underway to supplement the Knysna population with juvenile female elephants salvaged from culls in Kruger National Park, South Africa.

Kakum National Park and AssinAttandanso Wildlife Resource Reserve, Ghana

Little is known of the history of the forest elephant (*L. africana cyclotis*) population inhabiting this 347km² rainforest fragment, of which the southern border lies 30km inland from the city of Cape Coast, Ghana. Elephants were present locally at the time of

Table 1. Descriptions of the three sites.

Kakum	350km ²	Tropical rainforest	National Park/Resource Reserve
Addo	120km ²	Arid subtropical evergreen succulent scrub	National Park
Knysna	150km ²	Moist temperate Afromontane forest/ fynbos scrubs	State Forest

Table 2. Population bottleneck estimations.

Site	N 1995	Minimum N	Bottleneck Date:N	time since isolation
Kakum	100-150	?	no data	<100 years
Addo	212	11	1920:16 1931:11	>100 years
Knysna	3*	3	1920: 7-13 1950:4-7 1980:3	>200 years

thedemarcation of the Kakum and Assin-Attandanso Forest Reserves in 1933-1935; the elephant population was later estimated by Paijmans & Jack (1959) at about 100 animals. A recent survey (Dudley *et al.*, 1992) has estimated the current elephant population at 100-150 individuals.

Ivory was a major item of commerce in this region during colonial times, which explains the origin of the name Côte d'Ivoire (Ivory Coast) for the country bordering Ghana to the west. Intense ivory hunting during colonial times caused reduced modal tusk sizes in West African forest elephant populations; ivory trade records indicate that the largest size class of tusks was eliminated from many West African elephant populations (Sikes, 1971). Ivory poaching does not appear to have been significant in Kakum during the period 1980-1990, although local sources indicate that sporadic shooting of elephants for ivory had occurred some years earlier (Dudley *et al.*, 1992).

The Kakum elephants are the eastern-most surviving population of forest elephant in the Upper Guinean forest region, and now appear to be completely isolated from possible contact with other elephant populations. The survival of elephants in the Kakum region is attributed to the refuge provided by their rainforest habitat and the limited scale of agricultural development in the surrounding region prior to the time of the gazettement of the forest reserves during the period 1933-1935. [However, there has been a noticeable increase in crop-raiding by the Kakum elephants which is hypothesised to be associated with the long-term effects of logging (Barnes *et al.*, 1995)]. Reserve boundaries correspond more or less exactly with the upper limit of perennial surface water within the streams draining the catchment areas of these reserves (Paijmans & Jack, 1959). Elephants obtain drinking water during dry periods from small pools and boggy areas within the reserves and from perennial streams which demarcate some sections of the reserve boundaries.

The southern Cape

Ivory hunting and loss of habitat to agriculture had all but exterminated elephants in southern Africa by 1900 (Burton, 1968; Hall-Martin, 1992). The last elephant in the vicinity of the Cape peninsula was killed in 1704 and elephant populations west of the Knysna region were extirpated prior to 1800 (Hall-Martin, 1992). By 1775 the remaining Cape elephants had retreated into forests along the foothills of the OutinequaTsitsikamma coastal ranges and dense scrub-thickets of the Addo bush (Smithers, 1983).

Although elephants inhabiting the Addo and Knysna regions were afforded statutory protection in 1860, forestry officials in 1876 and 1889 reported the continued destruction of elephants (Smithers, 1983). The Cape region's elephant populations were approaching extermination by 1900 due to the cumulative effects of ivory hunting and eradication campaigns by farmers. By 1920 relict herds of elephants were still present only in the impenetrable scrub-thickets of Addo (near Port Elizabeth) and the densely forested foothills of the Outiniqua coastal mountains around the port of Knysna, South Africa. By 1930 there were only some 22 elephants surviving within the entire Cape region: 11 in the Addo bush and another 11 in the Knysna forest (Burton, 1968; Hall-Martin, 1992).

The Addo and Knysna elephant herds suffered severe population bottlenecks in conjunction with their decimation and isolation within disjointed fragments of their original habitat. Total founder populations of the existing elephant herds are thought to have numbered at most 11 individuals in Addo (circa 1931) and no more than 13, and possibly as few as four to seven individuals in Knysna (circa 1950), as shown in Figure 2 (Burton, 1968; Koen, 1982; Hall-Martin, 1992).

IMPLICATIONS FOR ELEPHANT CONSERVATION

The detailed historical data available for the Knysna and Addo elephant populations represent a unique opportunity for investigating the genetic consequences of bottlenecks and re-introductions within isolated elephant populations. These data could be used to assess the likelihood of prior population bottlenecks within populations of elephants like those of Kakum, for which past histories are uncertain. Such information could also prove valuable to the future management of genetic diversity in wild and captive ("domesticated") African and Asian elephants.

CONCLUSION

Elephants survived in Kakum, Addo and Kynsna because difficult terrain and/or dense vegetation afforded them refuge during the critical period of intense ivory hunting and expanding agricultural development during the 19th and 20th centuries. Subsequent government protection of habitat as forest reserves and (later) as national parks, rather than protected status for elephants per se, was the key factor in the survival of elephant populations at all three sites.

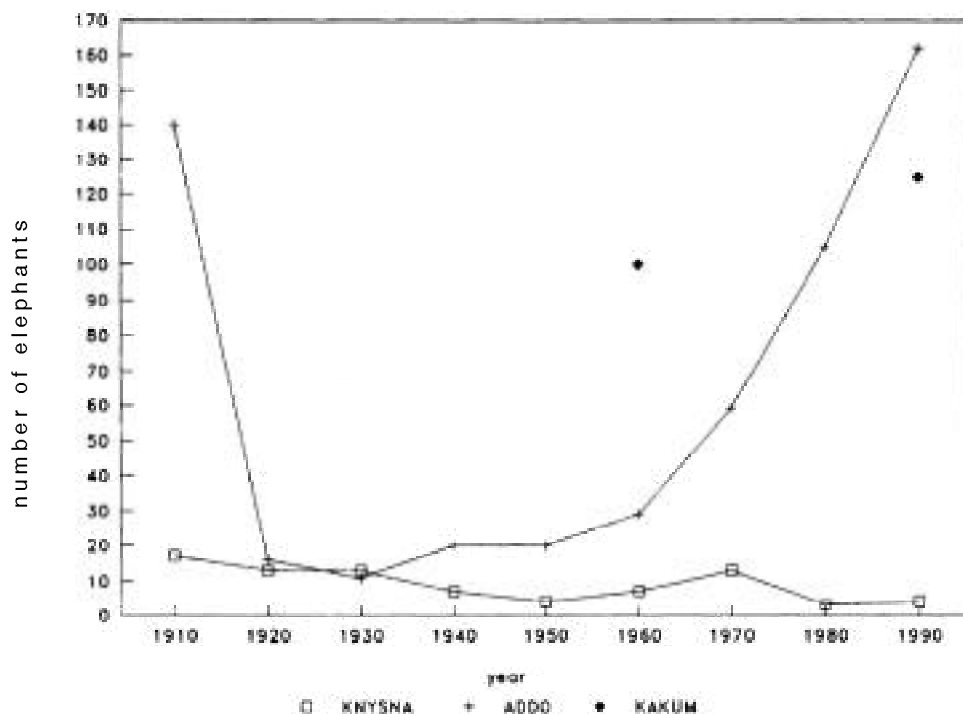

Figure 2 Population estimates for the three locations from 1910 to 1990.

ACKNOWLEDGEMENTS

The Sengwa Wildlife Research Institute of Zimbabwe provided access to recent publications concerning the Addo and Knysna elephants. W. Cooper, T. Erasmus, J. Koen, C. Higgins, A. Seydack and T. Stehle provided useful discussions and information concerning the Knysna elephants and their habitat. The Kakum elephant research received technical support from the Ghana Department of Game and Wildlife and the Department of Forestry. Armin Seydack, Ian Coulson, Reed Noss, Phil Kahl and Joshua Ginsberg provided helpful critiques of preliminary drafts.

REFERENCES

- Ambruster, P. & Lande, R. (1993) A population viability analysis for African elephant (*Loxodonta africana*): how big should reserves be? *Cons. Biol.* 7,602-610.
- Barnes, R.F.W., Azika, S. & Asamoah-Boateng, B. (1995) Timber, cocoa, and crop-raiding elephants: a preliminary study from southern Ghana. *Pachyderm* 19,33-38.
- Burton, C.M. (1968) History of elephants in the Eastern Cape. *Proceedings of the Knysna Elephant Symposium*, Appendix B. Wildlife Society, Port Elizabeth, South Africa.
- Cumming, D.H.M., Du Toit, R.F. & Stuart, S.N. (1990) *African Elephants and Rhinos: Status Survey and Conservation Action Plan*. IUCN, Gland, Switzerland.
- Dudley, J.P., Mensah-Ntiamoah, A.Y. & Kpelle, D.G. (1992) Forest elephants in a rainforest fragment: preliminary findings from a wildlife conservation project in southern Ghana. *Afr. J. Ecol.* 30,116-126.
- Eisenberg, J.F. (1981) *The Mammalian Radiations*. University of Chicago Press, Chicago.
- Eltringham, S.K. (1990) Wildlife carrying capacities in relation to human settlement. *Koedoe* 33,87-97.
- Hall-Martin, A.J. (1992) Distribution and status of African elephant in South Africa 1652-1992. *Koedoe* 35,65-88.
- Hall-Martin, A.J. (1993) (The Addo Elephants). *Custos* August 1993,17-19.
- Knight, M.H. & Hall-Martin, A.J. (1995) Helicopter surveys of Addo National Park, March and May 1995. Internal report, National Parks Board, Kimberley, South Africa.

Koen, J.H. (1982) The Knysna elephants: a relict population. *Elephant* 2,131 - 134.

Laws, R.M., Parker, I.S.C. & Johnstone, R.C.B. (1975) *Elephants and Their Habitats*. Clarendon Press, Oxford, England.

Olivier, R.C.D. (1978) Conservation of the Asian elephant. *Environ. Cons.* 5,156.

Newmark, W.D., Manyaza, D.N., Gamassa, D.G.M. & Sariko, H.I. (1994) The conflict between wildlife and the local people living adjacent to protected areas in Tanzania: human density as a predictor. *Cons. Biol.* 8,249-255.

Parker, I.S.C. & Graham, A.D. (1989) Men, elephants, and competition. *Symp. Zool. Soc. Lond.* 61,241-252.

Pajmans, K. & Jack, W.H. (1959) Greater Kakum Forest Reserves working plan, Vol I: Parts I, II, and III. Ghana Department of Forestry, Accra.

Pitman, C.R.S. (1934) *Faunal Survey of Northern Rhodesia with Special Reference to Game, Elephant Control and National Parks*. Government Printer, Livingstone.

Said, M.Y., Chunge, R.N., Craig, G.C., Thouless, C.R., Barnes, R.F.W. & Dublin, H.T. (1995) *African Elephant Database 1995*. IUCN, Gland, Switzerland.

Santiapillai, C. & Jackson, P. (1990) *The Asian Elephant: An Action Plan for its Conservation*. IUCN, Gland, Switzerland.

Seidensticker, J. (1984) Managing elephant depredation in agricultural and forestry projects. World Bank Technical Paper, World Bank, Washington D.C.

Sikes, S.K. (1971) *The Natural History of the African Elephant*. Weidenfield and Nicolson, London.

Smithers, R.H.N. (1983) *The Mammals of the Southern African Subregion*. University of Pretoria, South Africa.

Tchamba, M.N. & Mahamat, H. (1992) The effects of elephant browsing on the vegetation in Kalamaloué National Park, Cameroon. *Nature et Faune* 8,8-14.

Photo credit: Rich Weyehaeuser, WWF Photolibrary, Gland, Switzerland



Pachyderm

Notice to contributors

Pachyderm welcomes original manuscripts (not published elsewhere) dealing with the conservation and management of elephants and rhinos. All submissions are reviewed by referees. Manuscripts should preferably not exceed 4,000 words; shorter ones have a greater chance of being published. Contributions may be written in English or French and should be typed on one side of A4 paper, double-spaced with ample margins. Manuscripts may be submitted on IBM-compatible 3.5" diskettes in WP5.1. The full postal address of the first author should be included as well as the address of any other author.

Tables and figures should be submitted on separate sheets and the captions to illustrations typed out on another sheet. Figures should be black-and-white high quality graphics, suitable for reduction. Photographs should be unmounted, glossy prints of good quality. Abbreviations and references should be made using the same format provided by the *African Journal of Ecology*.

Pachyderm is the journal of the IUCN/Species Survival Commission (SSC) of the African Elephant, African published in *Pachyderm* do not necessarily reflect the views or opinions of the Specialist Groups, SSC, IUCN, the Editorial Board or the Editor.

Artwork by Development Communications Ltd., Nairobi
Colour separations by Repro-Scan Kenya, Nairobi
Printed by Signal Press Ltd Nairobi on 100gms cartridge paper